



INSTALLATION, USE AND MAINTENANCE MANUAL

CENTRIFUGAL FANS SERIES:

**LP../ , MP../ , HP../ ,
CL../ , CMP../ , CHP../**

AXIAL FAN SERIE:

AX../ , AXHP../

LAYOUTS

4 - 5 - 7 - 8 - 9 - 10 - 12 - 13

Translation of the Original
Italian Instructions



TABLE OF CONTENTS

1	GENERAL INFORMATION AND EQUIPMENT DESCRIPTION	5
1.0	SOME NOTES ON THE USER'S MANUAL	5
1.1	CONVENTIONAL SYMBOLS AND THEIR DEFINITION	6
1.2	RECIPIENTS OF THE MANUAL	7
1.3	SCOPE OF THE MANUAL	7
1.4	LIMITATIONS ON USE OF THE MANUAL	7
1.5	WARRANTY CONDITIONS	8
1.6	GENERAL PROVISIONS	8
1.7	REPRODUCTION LIMITATIONS AND COPYRIGHT	8
1.8	CHARACTERISTICS OF OPERATORS AND LANGUAGE USED	9
1.9	HOW TO STORE THE MANUAL	9
1.10	HOW TO UPDATE THE MANUAL	9
1.11	PRELIMINARY ARRANGEMENTS THAT MUST BE PROVIDED BY THE CLIENT (AS STIPULATED IN THE CONTRACT)	10
1.12	GENERAL DELIVERY NOTES	10
1.13	RESPONSIBILITY OF HDF	10
2	SAFETY PROVISIONS	13
2.1	PERSONAL PROTECTION (PPE)	13
2.2	SAFETY LABELS, PROHIBITIONS AND OBLIGATIONS	14
2.3	RESIDUAL RISKS	15
2.3.1	LIST OF RESIDUAL RISKS	15
2.3.2	LABELS SHOWING RESIDUAL RISKS, RESTRICTIONS AND OBLIGATIONS	16
2.4	GENERAL SAFETY PROVISIONS	17
2.5	SPARE PARTS	22
2.6	SAFETY DEVICES INSTALLED ON THE FAN	22
2.7	NOISE LEVEL	23
2.8	INTENDED USE	23
2.9	UNINTENDED USE	23
2.10	WHAT YOU SHOULD ALWAYS DO!	23
2.11	WHAT YOU SHOULD NEVER DO!	24
2.12	FINAL PART	25
3	TECHNICAL DESCRIPTION AND SPECIFICATIONS	26
3.1	TECHNICAL DESCRIPTION	26
3.2	TECHNICAL DATA NOMENCLATURE	26
3.3.A	TYPE OF IMPELLERS FOR CENTRIFUGAL FAN	27
3.3.B	TYPE OF IMPELLER FOR AXIAL FAN	27
3.4	ARRANGEMENTS	28
3.5	DISCHARGE POSITION (FAN OUTLET POSITION)	29
4	LIFTING AND INSTALLATION INSTRUCTIONS	31
4.1	FOREWORD	31
4.2	HANDLING OF THE PACKED FAN AND ITS PARTS	34
4.2.1	HANDLING OF PACKING CASES AND PALLETS WITH A FORKLIFT TRUCK	35
4.2.2	HANDLING OF PACKING CASES AND PALLETS WITH OVERHEAD CRANE AND CABLES	36
4.2.3	HANDLING FROM A CONTAINER	37
4.3	UNPACKING	38
4.4	STORAGE	39
4.5	DISPOSING OF THE PACKAGE	40
4.6	HANDLING OF THE UNPACKED FAN	40
4.7	HANDLING OF LOOSE OR LIGHT PARTS	42
4.8	FOUNDATIONS	42
4.8.1	REINFORCED CONCRETE FOUNDATION	42
4.8.2	FOUNDATION WITH STEEL FRAMES	43

4.8.3	ANTI-VIBRATION MOUNTINGS.....	43
4.9	INLET AND OUTLET DUCTS	44
4.10	POSITIONING AND INSTALLATION OF THE FAN	45
4.10.1	INSTALLATION METHODS (UNI EN ISO 13349).....	45
4.10.2	CHECKS BEFORE THE ASSEMBLY.....	46
4.10.3	PRELIMINARY OPERATIONS BEFORE FAN FIXING	46
4.11	INDICATIONS FOR THE CONNECTION TO THE MACHINE.....	47
4.11.1	CONNECTION OF THE PNEUMATIC EQUIPMENT (AIR).....	47
4.11.2	CONNECTION OF THE MOTOR AND/OR ELECTRICAL EQUIPMENT	48
4.11.3	CONNECTION TO THE EXTRACTION SYSTEM	48
5.	COMMISSIONING.....	49
5.1	FIRST START-UP AND TESTING	49
5.2	PRELIMINARY CHECKS.....	49
5.3	START-UP PROCEDURES	50
5.4	CHECKS DURING START-UP	50
6.	USE AND OPERATION.....	51
6.1	CHECKS BEFORE SWITCH-ON.....	51
6.2	SWITCHING ON THE FAN.....	51
6.3	CHECKS AFTER SWITCH-ON	52
6.4	SWITCHING OFF THE FAN.....	52
6.5	EMERGENCY STOP.....	53
7.	MAINTENANCE, CLEANING AND LUBRICATION	54
7.1	FOREWORD	54
7.2	SCHEDULED MAINTENANCE	57
7.2.1	FAN CASING CLEANING.....	59
7.2.2	IMPELLER CLEANING (FOR CLEAN FLUIDS).....	59
7.2.3	IMPELLER CLEANING (FOR DUSTY FLUIDS).....	60
7.2.4	IMPELLER CONDITION CHECK.....	60
7.2.5	DAMPERS' CLEANING	61
7.2.6	BEARINGS AND HOUSINGS	61
7.2.6.1	ANTIFRICTION BEARING LUBRICATION WITH GREASE (SEPARATED BEARINGS)	62
7.2.6.2	BEARING HOUSING (MONOBLOCK) LUBRICATION WITH GREASE.....	64
7.2.6.3	ANTIFRICTION BEARING LUBRICATION WITH OIL.....	65
7.2.6.4	LUBRIFICANT TYPES AND MAINTENANCE NOTES	66
7.2.7	FASTENING OF ALL FIXED PARTS	69
7.2.8	TOOTHED BELTS.....	70
7.2.9	V-BELTS	71
7.2.10	FAN VIBRATION CHECK	73
7.2.11	IMPELLER ASSEMBLY.....	74
7.2.12	IMPELLER DISASSEMBLY	74
7.2.13	MOTOR REVISION	75
7.2.14	COUPLING REPLACEMENT.....	76
7.2.14.1	LUBRICATION OF STANDARD GEAR COUPLING "MAINA" – GO-A.....	77
7.2.14.2	LUBRICATION OF LAMELLAR COUPLINGS	78
7.2.15	CHECK OF ALL THE ELECTRICAL SYSTEM COMPONENTS	79
7.2.16	CHECK OF THE LEGIBILITY OF THE WARNING LABELS FOR RESIDUAL RISKS, RESTRICTIONS AND OBLIGATIONS.....	79
7.2.17	INSTALLATION OF THE INLET CONTROL DAMPER.....	79
7.2.18	SEALS MAINTENANCE AND START UP.....	81
7.2.19	THERMOCOUPLE MAINTENANCE AND REGULATION – PT100.....	84
8.	TECHNICAL SUPPORT INFORMATION.....	88
9.	DISMANTLING AND DISPOSAL.....	89
10.	SPARE PARTS	90



11. TROUBLESHOOTING	91
12. ATEX	94
12.1 WARNINGS	94
12.2 CONSTRUCTION FEATURES.....	95
12.3 INTERNAL AND EXTERNAL ZONES	95
12.3 ATEX MARKING – NAME PLATE.....	96



1 GENERAL INFORMATION AND EQUIPMENT DESCRIPTION

1.0 Some notes on the User's Manual

The USER'S MANUAL supplied is not an accessory of the Fan, and is an INTEGRAL PART of the Fan and is a SAFETY PROVISION.

For this reason, you need to keep it in good condition, near the Fan and give it to any operator, user or subsequent owner, so they can always have all the necessary information available for which it was manufactured and also because it is a support for system use in maximum SAFETY.

The Manual must be updated as indicated by **HDF S.r.l.**

The manual must not be damaged, it must remain intact (NO torn pages) and must be kept protected from humidity and heat.

During consultation, you need to avoid making it greasy or making it illegible.

To make its consultation simpler, the manual was sub-divided into chapters, to facilitate use per employee type and to ensure each phase is well articulated.

Each topic was further subdivided into numbered points, which are sometimes referenced with drawings.

The passages requiring greater attention are highlighted with conventional symbols on the left of the page.

HDF S.r.l. uses this convention to draw the reader's attention to ATTENTIONS, WARNINGS AND DANGERS that concern him.

Please note that the illustrations in this Manual, included in order to facilitate the identification of the described parts, might not be completely similar to the Fan you have purchased for obvious reasons of generalisation.

In case of loss or damage, replacement documentation must be requested directly to:

HDF S.r.l.
Servizi Generali Qualità

Via G. Meani 119
20861 Brugherio (MB)

Tel.: +39 039 57 841 11

Fax.: +39 039 57 841 99

Email: service@hdfans.it













info@hdfans.it



Web: <https://www.hdfans.it/>

VAT No. and Tax Code IT 02120370123

specifying the serial number that can be found on the plate affixed to the fan.

1.1 Conventional symbols and their definition

	The Use and Maintenance Manual contains certain symbols: they are listed below together with their meaning.
	GENERAL DANGER It signals to relevant staff that the operation described, if not carried out in compliance with the safety standards, can be a source of possible injury or harm to people.
	ELECTRIC SHOCK HAZARD It signals to relevant staff that the operation described, if not carried out in compliance with the safety standards, can be a source of possible injury or harm to people due to electric shock.
	EX HAZARD It indicates the risk of explosion.
	NOTE It signals to relevant staff information of major importance and, if not complied with, can cause damage to various parts of the Fan.
	WARNING It signals to relevant staff information that, if not complied with, can cause serious injury to people
	ADVICE It refers to a working method tested in the factory, knowing well that each Operator will further develop his/her own way of working.
	OPERATOR OR DRIVER OF THE MACHINE It identifies qualified, professionally trained staff authorised in compliance with the regulations in force in the country of use to start, use, fine tune (with the guards enabled and the machine off) and shut-down the machine following the instructions in this manual and using the required personal protective equipment (PPE) It is therefore prohibited for the operator to perform operations that are the responsibility of the Maintenance Technician.
 	OPERATOR RESPONSIBLE FOR MOVEMENT Qualified, professionally trained operator authorised in compliance with the regulations in force in the country of use to operate forklifts, overhead cranes or cranes to safely transport, handle and unpack the Fan and/or parts of it using the required personal protective equipment (PPE).
	MECHANICAL/PNEUMATIC MAINTENANCE TECHNICIAN Qualified technician, authorised to perform adjustments and maintenance and/or repair works on mechanical/pneumatic parts, even with the guards disabled (with the consent of the Department Manager) following the instructions in this manual and using the required personal protective equipment (PPE).
	ELECTRICAL MAINTENANCE TECHNICIAN OR QUALIFIED PERSON (See EN 60204-1:2006) Qualified Technician (electrician who meets the professional technical requirements set out by the regulations in force), authorised to perform adjustments and maintenance and/or repair works on electrical devices even when energised and even with the guards disabled (with the consent of the Department Manager) following the instructions in this manual and using the required personal protective equipment (PPE).
	MAINTENANCE TECHNICIAN OF HDF S.R.L. (Non-routine maintenance)

<p>Qualified technician of HDF S.r.l. authorised to provide technical assistance and to carry out routine and non-routine maintenance works and/or operations not described in this manual and that require specific knowledge of the Fan, using the required personal protective equipment (PPE) The changes made will be documented and a copy of the documentation will be issued to the Client.</p>
 <p>DEPARTMENT MANAGER OR SAFETY MANAGER See Legislative Decree no. 81/2008 dated 9.04.2008.</p>
 <p>OBLIGATION TO READ THE MANUAL Reading of the Safety Specifications and in particular, the entire Instructions Manual is compulsory.</p>
 <p>NON-ROUTINE MAINTENANCE OPERATIONS Any maintenance intervention highlighted by the symbol to the side should be requested to HDF S.r.l.</p>

1.2 Recipients of the Manual

By convention, for the purposes of this Manual, the Partly completed machinery will be referred to as "FAN"

The intended users of the manual and, in general, of all the technical documentation with which the Fan is equipped, are:

- the drivers (Operator);
- the Technicians in charge with maintenance (Maintenance Technician);
- the staff assigned to manage the system (i.e. organisation of manufacturing, planning of maintenance, supply of spare parts, etc.);
- the staff involved in initial assembly operations and final disposal of the Fan;
- the owner;
- the Technical Manager;
- the Safety Engineer (Safety Manager).

1.3 Scope of the Manual

The scope of this document is to promote safe, efficient and effective use of the Fan. In particular, it intends providing intended users with a useful tool to:

- identify the Fan;
- get to know the safety equipment on the Fan, the behaviour to observe to maintain safe conditions, any Residual Risks, reference standards, etc.;
- learn about the main parts of the Fan, both regarding the reference terminology used and the different functions they may carry out;
- handle and transport the Fan correctly, whether during the initial installation or upon final dismantling;
- set up an adequate maintenance program.

The Manual divided into 12 Chapters is in turn sub-divided into Paragraphs, and possibly further divided into Sub-paragraphs.

Chapters, Paragraphs and Sub-paragraphs are coded with progressive numbers.

1.4 Limitations on use of the Manual

The Manual does not replace the remaining technical documentation; it is supplementary to it, integrates it and relates it to the context of the Fan.

Reading the manual does not relieve the manufacturer from the obligation to carry out general training and coordinate the staff in a safe manner.

It is assumed that the intended users of this document have suitable ability and professional preparation for the correct interpretation of the instructions, the indications and illustrations it contains. Given the characteristics of the Partly Completed Machinery, the training provided by this Manual cannot disregard adequate professionalism and experience, which is gradually achieved in the field.

In relation to reading this Use and Maintenance Manual in its entirety, it may not suffice to know, operate and manage the Fan at its best. It should be considered unless proven to the contrary, an introduction necessary for all the indicated intended users, so that each can acquire minimum training necessary to operate the Fan, in relation to personal competence, in an adequate manner and especially in safe conditions.

1.5 **Warranty conditions**



To know the detailed information on the warranty conditions, refer to the sales contract. Unless otherwise specified, the warranty lasts 1 year from the date of delivery.

It does not cover:

- the normal wear parts (e.g. bearings, vanes, rotary seal);
- defects resulting from chemical corrosion or galvanic currents

The warranty becomes null and void in case of:

- modifications made to the Fan without the prior consent of HDF S.r.l.;
- use of wear parts or spare parts not supplied by HDF S.r.l. (especially during the warranty period);
- improper storage;
- incorrect installation or failure to comply with the installation requirements reported herein.

In order to benefit from the warranty provided by **HDF S.r.l.**, the user must observe the instructions reported in this Manual and in particular:

- always operate within the limitations on use of the Fan;
- always carry out constant and diligent maintenance;
- assign only properly trained operators, with certified capacities and skills to operate the Fan.



HDF S.r.l. cannot be held in any way liable for any accidents, damage or injuries that could occur to people and/or property.

1.6 **General provisions**

The user should inform the staff responsible for Fan operation of the following topics relating to safety provisions:

- risk of accidents;
- devices available for Operator safety (PPE);
- general safety regulations or provisions in the International Directives and legislation in force in the destination Country of the Fan.

The Operator, the staff responsible for maintenance and cleaning, etc., must strictly comply with the Safety standards in the destination Country of the Fan.

1.7 **Reproduction limitations and copyright**

All rights reserved to **HDF S.r.l.**

The structure and contents of this manual may not be reproduced in part or whole without the

express permission of **HDF S.r.l.**

It is also forbidden to copy it on any support (magnetic, magnetic-optical, optical, micro-film, photocopies, etc.) or transfer it to third parties.

The Operator, the staff responsible for maintenance and cleaning, etc., must strictly comply with the Safety standards in the destination Country of the Fan.

1.8 **Characteristics of Operators and language used**



To understand the instructions (text and illustrations), operators must have (or acquire through adequate training and information) at least the following characteristics:

- general and technical culture of sufficient level to read and understand the content of the Manual in the parts regarding his/her tasks and correctly interpret the drawings and diagrams;
- ability to understand and interpret the symbols and pictograms;
- know the main hygiene, accident prevention and technological standards;
- overall knowledge of the Fan;
- how to behave in case of an emergency, where to find the personal protective equipment and how to use it correctly.



The Operator, the staff responsible for maintenance and cleaning, etc., must strictly comply with the Safety standards in the destination Country of the Fan.

ATTENTION:

Maintenance technicians, other than the previous, must also have good technical preparation and have specific and specialist technical knowledge (mechanical, electrical) necessary for the tasks planned in the Manual

1.9 **How to Store the Manual**



Keep this Manual in an easily accessible location, near the Fan and known to all users (Operators and staff responsible for maintenance).

The Operators and Maintenance staff must be able to consult the Manual and the attachments quickly, in any situation.

WARNING

The Manual is an integral part of the Fan. Therefore:

- it must be kept intact (in all its parts) without making any changes to any of the parts such as corrections, deletions, abrasions or otherwise which could compromise clear reading of the manual;
- it must follow the Fan up to demolition (also in the case of movements, sale, hire, rental, etc.);
- it must be kept up to date and all changes must be noted;
- it must be available to anyone working on the Fan;
- it must be kept updated following design modifications made with the consent of **HDF S.r.l.**

1.10 **How to Update the Manual**

The Use and Maintenance Manual reflects the technical status at the time of Fan sale.

The Manufacturer reserves the right to make changes to the Fan and, as a result, to the relevant Manuals, without being obliged to update the previous editions.

The user can, however, request information and updates which, when released, become an integral part of the Use and Maintenance Manual.

If the Fan is transferred to another owner, it must be accompanied by this Manual and **HDF S.r.l.** must be notified of the sale to ensure that the new owner receives any subsequent additions.

1.11 Preliminary arrangements that must be provided by the Client (as stipulated in the contract)

The Client (user) must prepare, under his responsibility, the installation site and the auxiliary system works necessary for the operation of the Fan as listed below:

- preparation of premises;
- any lifting devices suitable for moving the Fan;
- any safety devices installed upstream/downstream of the power supply lines (required by the legislation in force);
- preparation of the auxiliary services suitable for Fan operation;
- any tools and consumable materials necessary for assembly and installation.

1.12 General delivery notes

The Fan can be shipped on pallets, packed in a packing case or a crate.

Check that:

- the package is intact;
- the Fan is intact; in particular: the frame, the impeller, the motor;
- the supply corresponds with order specifications (see packing list or bill of materials).



In the event of damage or missing parts, immediately inform and provide details/photos to **HDF S.r.l.**, the carrier and/or the insurance company.

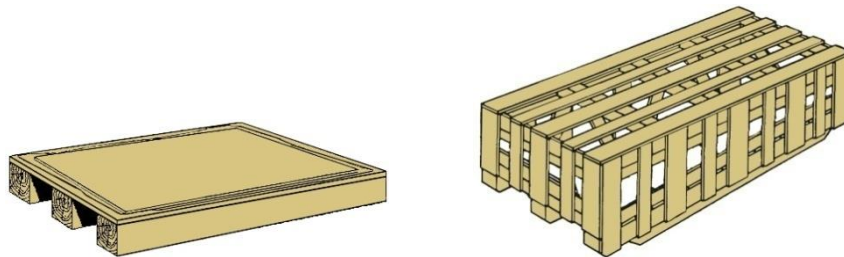

1.13 Responsibility of HDF

The instructions given in this manual do not replace but integrate the obligations for compliance with the legislation in force concerning the safety and accident prevention standards.

With reference to the information provided in this manual, HDF disclaims any liability in case of:

- failure to comply with the national safety and accident prevention regulations;
- failure to respect or incorrect application of the instructions reported in this manual;
- power supply failures;
- unauthorised changes to the machine;
- tampering with or removal of the guards/safety devices;
- use by untrained staff.

The intended use and configurations of the machine are the only ones allowed by HDF.

Do not attempt to use the Fan in other ways than those indicated herein.

1.14 Identification of the Fan and Manual number

- The job number and abbreviation of the Fan model were outlined on the identification plate.
- The number of this Manual is found on the cover and on the title page of the Manual.
- Write the serial number, the abbreviation of the fan model and the Manual number in a safe place, to request a copy if lost.

type: CN - STD

CENTRIFUGAL



HDF S.r.l.
Via Nazionale, 5/C
Zona Artigianale
23030 Chiuro (SO) - ITALY
tel/phone: +39 0342 484011
fax: +39 0342 483059
info@hdfans.it
www.hdfans.it

VENTILATORE TIPO FAN TYPE		COMMESSA JOB	
MATRICOLA SERIAL NUMBER		ANNO COSTRUZIONE MANUFACTURE YEAR	
POTENZA INSTALLATA INSTALLED POWER		T. FLUIDO DI PROCESSO FLUID OPERATING T.	
ROTAZIONE ROTATION		RPM NOMINALI RATED RPM	

76

110

tipo: AX - STD

ASSIALI



HDF S.r.l.
Via Nazionale, 5/C
Zona Artigianale
23030 Chiuro (SO) - ITALY
tel/phone: +39 0342 484011
fax: +39 0342 483059
info@hdfans.it
www.hdfans.it

VENTILATORE TIPO FAN TYPE		COMMESSA JOB	
MATRICOLA SERIAL NUMBER		ANNO COSTRUZIONE MANUFACTURE YEAR	
POTENZA INSTALLATA INSTALLED POWER		T. FLUIDO DI PROCESSO FLUID OPERATING T.	
DIREZIONE FLUSSO FLOW DIRECTION		RPM NOMINALI RATED RPM	

76

110



The documentation was prepared in compliance with harmonised standard UNI-EN ISO 12100:2010 paragraph 6.4.5.

The Fan was designed and built in compliance with the Machinery Directive 2006/42/CE. The side guards required by the Directive must be provided by the end user if not included in the scope of supply. It is strictly forbidden to start the Fan without installing the guards.



WARNING

It is forbidden to remove the identification plate on the Fan and/or exchange it with other plates on the machine.

Reference directives

- Machinery Directive 2006/42/CE of the European Parliament and of the Council of 17 May 2006 on machinery and amending Directive 95/16/CE (recast)
- Directive 2014/30/UE of the European Parliament and of the Council of 26 February 2014 on the harmonisation of the laws of the Member States relating to electromagnetic compatibility (recast)
- Directive 2014/35/EU of the European Parliament and the Council of 26 February 2014 concerning the harmonisation of laws of the Member States relating to the making available on the market of electrical equipment designed for use within certain voltage limits (recast)
- Directive 2009/125/CE of the European Parliament and of the Council of 21 October 2009 establishing a framework for the setting of ecodesign requirements for energy-related products (recast).
- Directive 2014/34/UE of the European Parliament and of the Council of 26 February 2014 on the harmonisation of the laws of Member States relating to equipment and protective systems intended for use in potentially explosive atmospheres (recast)







Reference standards

- UNI EN ISO 12499: 2009 Industrial fans - Mechanical safety of fans - Guards.
- UNI EN ISO 12100: 2010 Safety of machinery – General principles for design – Risk assessment and risk reduction.
- UNI EN ISO 14120:2015 Safety of machinery - Guards - General requirements for the design and construction of fixed and movable guards
- UNI EN 349:2008 Safety of machinery - Minimum gaps to avoid crushing of parts of the human body.
- UNI EN ISO 13857:2008 Safety of machinery. Safety distances to prevent hazard zones being reached by upper and lower limbs.
- ISO 1940-1: 2003 Mechanical vibration -- Balance quality requirements for rotors in a constant (rigid) state -- Part 1: Specification and verification of balance tolerances
- ISO 14694:2003 Industrial fans -Specifications for balance quality and vibration levels
- CEI EN 60204-1: 2006 Safety of machinery - Electrical equipment of machines - Part 1: General requirements.
- UNI10893: 2000 Technical documentation of product Instructions for use Structure and order of content.
- UNI ISO 10015 Guidelines for training.
- UNI EN ISO 7010:2012 Graphical symbols Safety colours and safety signs. Registered safety signs
- UNI11394: 2011 Technical information - Evaluation system for instructions for use of technical goods"













2 SAFETY PROVISIONS

2.1 Personal protection (PPE)

The presence of a symbol from those indicated below on the Fan or on the Manual requires compulsory use of the protection devices by the operator, due to an implicit risk of an accident.

	MANDATORY USE OF SUITABLE WORK GLOVES FOR THE ACTIVITY TO CARRY OUT	<ul style="list-style-type: none"> • HANDLING • FINE TUNING • CLEANING • LUBRICATION • MAINTENANCE
	THE USE OF WORK SHOES IS COMPULSORY	<ul style="list-style-type: none"> • OPERATORS • MAINTENANCE TECHNICIANS
	WEARING OVERALLS CLOSED AT THE WRIST AND/OR WITHOUT LOOSE PARTS IS COMPULSORY	<ul style="list-style-type: none"> • OPERATORS • MAINTENANCE TECHNICIANS
	WEARING A PROTECTIVE HELMET IS COMPULSORY	<ul style="list-style-type: none"> • OPERATORS • MAINTENANCE TECHNICIANS
	WEARING NOISE PREVENTION EARMUFFS IS COMPULSORY	<ul style="list-style-type: none"> • OPERATORS • MAINTENANCE TECHNICIANS
	WEARING A PROTECTIVE MASK IS COMPULSORY	<ul style="list-style-type: none"> • OPERATORS • MAINTENANCE TECHNICIANS

2.2 Safety labels, prohibitions and obligations

SIGN	MEANING	SIGN	MEANING
	Danger automatic start-up Depending on the type of electrical connection and control logic, the fan may start automatically and unexpectedly.		Do not step on the fan It is strictly forbidden to step on the fan or on parts of it.
	Danger hot surface Risk of scalding and/or burning in case of accidental contact with the casing and bearing during fan operation or just after shut-down.		Do not reach in It is strictly forbidden to reach inside the fan.
	Finger cutting and/or crushing hazard Risk of finger cutting and/or crushing in case of accidental contact with the impeller or the transmission during routine maintenance.		Do not remove the guards when the fan is working It is strictly forbidden to carry out maintenance operations with the machine in motion.
	Danger impeller in motion even if disconnected from power supply Even if the fan is off, the impeller might still move due to the air coming in through the openings and passing through the fan.		Crane lifting point The fan must be lifted using the points marked with this sign.
	High noise level Danger of exposure to noise for the operators: fans represent a source of noise.		Disconnect mains plug from electrical outlet before carrying out any work Disconnect the power supply and ensure that the fan is in a "zero energy state" before carrying out any work on the fan.
	Connect an earth terminal to the ground It is mandatory to connect the earth terminal to the grounding system.		
	Earmuffs must be worn The noise level exceeds 80 dB(A); earmuffs must be worn.		Compulsory restoration of guards Refit and/or reset the guards before starting the fan.

2.3 Residual Risks

2.3.1 List of residual risks

When the Fan is working, it must be completely isolated and safe for the users. During TUNING, CLEANING, LUBRICATION and MAINTENANCE, dangerous situations may arise since you are in a danger zone. Although **HDF S.r.l.** provided additional safety systems to prevent access to danger zones, some parts that require fine tuning, cleaning, lubrication and maintenance operations still present residual risks.



Danger of burns

The fan poses a risk of scalding by accidental contact with the electric motor or with the fixed guard of the bearing (due to prolonged use of the fan): they can reach high temperatures >65°C.



Danger of crushing

If the operators fail to observe the instructions reported in this manual, especially during maintenance operations, there is a danger of injury by contact with moving parts even if the fan is in a zero energy state.

Danger of crushing

If the operator fails to observe the instructions reported in this manual, he might get dragged against the inlet protection grid by the air taken in. Observe the procedures reported herein and avoid going near the fan inlet while in motion.



High vibration risk

If the operator fails to respect the instructions reported herein, there is a risk of strong vibrations during fan operation.



High noise level

Danger of exposure to noise for the operators: fans represent a source of noise. In compliance with the regulations in force, the employer must assess the operators' exposure to the sources of noise present at the fan installation site. If the noise level exceeds 80 dB(A), the operators must wear adequate earmuffs; if the noise level exceeds ≥ 100 dB(A), the operators are allowed to approach the fan only when stopped or in a zero energy state even when wearing earmuffs.











2.3.2 Labels showing residual risks, restrictions and obligations



HDF has placed danger, restriction and specification signs near the relevant zones, repeated throughout the Manual.

These signs or instructions must be complied with, followed and, in the event of wear or if in any way illegible, must be immediately replaced.

Only technicians and qualified staff can carry out these operations.

The table below indicates the type of sign, in addition to the generic and electric shock hazards, its meaning and where it is placed.

PICTOGRAM	MEANING	LOCATION
	BURN HAZARD	FIXED GUARDS
	PROTECTIVE GLOVES MUST BE WORN	
	DANGER OF CRUSHING	NEAR THE IMPELLER
	PROTECTIVE GLOVES MUST BE WORN	
	HIGH VIBRATION RISK	AT THE FAN
	DANGER OF CRUSHING	FIXED SIDE GUARD
	PROTECTIVE GLOVES MUST BE WORN	
	COMPULSORY RESTORATION OF GUARDS IT IS FORBIDDEN TO CARRY OUT MAINTENANCE OPERATIONS ON MOVING PARTS	
	HIGH NOISE LEVEL	AT THE FAN
	EARMUFFS MUST BE WORN	

	DANGER OF ELECTRIC SHOCK	AT THE MOTOR/ ELECTRICAL PARTS
	CRANE LIFTING POINT	AT THE CONNECTION POINTS USED TO INTERFACE WITH LIFTING EQUIPMENT

2.4 General Safety Provisions

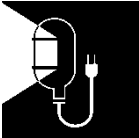

For cleaning, lubrication and maintenance operations in dark places, you should use portable lamps.

DEFINITION OF DANGER ZONE:

Zone inside and/or near the Partly Completed Machinery where the presence of an exposed person poses a risk or danger to the health and safety of that person (as described in Directive 2006/42/EC Ann. I par. 1.1.1).

DEFINITION OF DANGEROUS SITUATION:

Any situation in which a person is exposed to at least one danger (as described in Standard UNI EN ISO 12100:2010).

The Fan can be installed in closed or open environments equipped with all the facilities provided for by the applicable legislation in the Country of installation.

Before installing the Fan and all its parts, the installer must ensure that the floor on which it is to be installed is able to withstand its weight and it meets all the necessary technological requirements (see Chapter 3 "Technical Specifications").

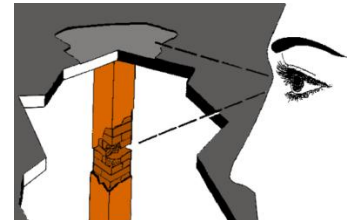

Carefully read the Chapter Safety Provisions in this Instructions Manual and in particular the instructions relating to:

- warning, restriction and obligation labels;
- Operator or driver of the Machine;
- Mechanical maintenance technician;
- Electrical maintenance technician or qualified person;
- power switch function;
- Emergency-Stop pushbutton functions;
- sensor function;
- fine tuning;
- maintenance.

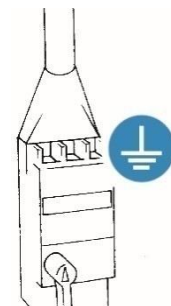

The installer must check that the electrical system where the Fan will be installed is provided with good earthing, sufficient for the rated power consumption and, otherwise, adjust said system. The system which will connect the fan to the mains must be CE marked.



For handling of parts of the unpacked Fan, please refer to Chapter 4 "Lifting and installation instructions" of this Manual.
 Never lift the components using their casings or protruding parts as connection points.
 Only use the lifting devices listed in Chapter 4 of this Manual.



Remember that during movement the coated and processed parts should be protected with cardboard, wood or rags

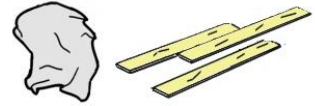

For maintenance, cleaning, lubrication, put the machine in ZERO ENERGY STATE (unless otherwise stated), isolate the area and affix signs stating work in progress to the main switch and the Fan. Also, disconnect the transmission coupling and/or remove the drive belts.



The installation, assembly, fine tuning and non-routine maintenance of the Fan must be carried out only by **HDF** Technical staff or by Trained technical staff, fully aware of the procedures and means to be adopted



The staff in charge with transport, positioning, fine tuning for production, maintenance and cleaning must always wear work gloves, safety shoes and helmet



During:

- Transport
- Positioning
- Installation
- Fine tuning for production
- Maintenance, lubrication and cleaning
- pay utmost attention to protruding parts



RISK OF HEAD OR UPPER LIMB INJURY.

For any problems that may arise during fine tuning and during the manufacturing cycle, press the EMERGENCY-STOP button

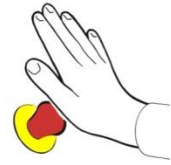

Never rest or sit on any part of the Fan, neither when the parts are moving nor when the same are at a standstill. It is forbidden to climb on the fan. Use a ladder, an adequate scaffolding and a man basket to access the top side of the machine.

Do not place containers with liquids near the electrical parts (for example the electric control panel, motors, etc.).

For any problems that may arise during fine tuning and during the manufacturing cycle, press the OFF button.

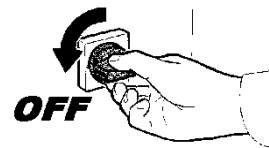

During the manufacturing cycle, NO OTHER PERSON CAN STAY NEAR THE FAN.

You can carry out visual inspections and operating checks during the manufacturing cycle.



Adjustment, maintenance and/or replacement operations or other interventions on the Fan must be carried out only by Client's Maintenance Technician, who must always wear protective gloves, safety footwear, helmet and goggles (if necessary) and pay utmost attention.

For no reason, tamper or inhibit or disconnect the micro-switches or any other safety devices, do not create by-passes and do not use safety devices for purposes other than those established and for which they were installed. Periodically check their efficiency



For tuning, cleaning and maintenance operations, always employ ONE PERSON ONLY, **NEVER MORE THAN ONE PERSON**, (unless otherwise specified).



Where possible, always wear goggles, adequate gloves, safety fo as needed.



Furthermore, you need to wear overalls closed at the wrist. If you have long hair, tie it up.





In any case, do not wear objects and/or clothing that is loose and/or with ties (collar, watches, ruffled shirt, ties, etc.); it is forbidden to wear objects that may get entangled in the parts of the fans.

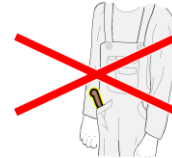
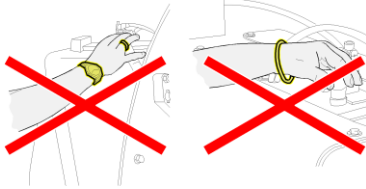

Remember that after any cleaning, lubrication, adjustment and maintenance operation, you must reset all safety devices and install and/or close all the protective casings (doors).



During maintenance and cleaning, the Machine must be in zero energy state and it is compulsory to isolate the area and affix the "work in progress" sign.

Put a sign on the main switch and on the door. Disable the transmission mechanically (disconnect the coupling and/or the belts).

The fan is a rotating machine that may become a source of danger to people and/or property if used improperly.



WARNING

DANGER OF CRUSHING/SHEARING:

If intervention is necessary, always wait for the impeller to stop. IT TAKES SEVERAL MINUTES. FOR THE IMPELLER TO STOP DO NOT remove the railing or the duct.

WARNING

PROJECTION HAZARD

Balance weight detachment or impeller breakage due to foreign objects sucked into the fan may pose a risk of projection of material fragments.

Therefore, the pipes must be suitably protected to prevent the entry of objects into the fan.

As per ISO 5801, in the case of installation type A, B or C, the inspection doors must be kept closed during fan operation and the inlet and outlet openings must be equipped with appropriate guards.

The presence of openings may result in personal injuries and foreign objects being sucked into the fan.

Do not stand within 5 m of the fan when it is on. Do not stand in the vicinity of the impeller. If you have to pass by near the impeller, stay at a distance of at least 5 m from it.



**WARNING
DANGER OF CRUSHING**

Wear protective gloves.
During fan operation, do not:
- remove the guards
- touch the drive belts.



**WARNING
DANGER OF BURNS:**

Pay utmost attention to the motor: it can reach temperatures of about 60/70°C.

Pay utmost attention to the bearings/pillow block: they can reach temperatures of about 80/100°C.

Always wait for the hot parts to reach ambient temperature.



If immediate intervention is necessary:
WEAR BURN-PROOF GLOVES.



The operator must take care of the space and the floor around the Fan ensuring it is always clean, to avoid slipping and as a result impacts and/or falls.
The floor, other than being clean, must be dry.

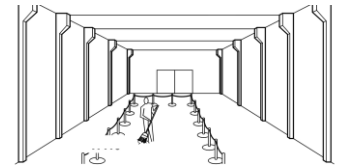

Do not tamper or disable or disconnect, for any reason, the safety micro-switches or any other safety devices (fixed and movable guards), do not create by-passes and do not use safety devices for purposes other than those set out and for which they were installed. Periodically check their efficiency

Never reach into the guards during the manufacturing cycle.

In particular:

- a) it is strictly forbidden to remove the side guards;
- b) do not remove the guard of the drive belt.



NEVER use high-pressure washers for cleaning.



2.5 **Spare parts**

Only use **HDF** original spare parts if worn and/or broken pieces must be replaced.

To search and proceed to order, refer to the Spare Parts List or contact HDF srl – Sales Department. HDF S.r.l. shall not be held liable for any machine malfunction in case of use of non-original spare parts.

This will also void the warranty and render the EC declaration of conformity null.



2.6 **Safety devices installed on the Fan**

The Fan is equipped with the following safety devices:

- fixed guards, designed and manufactured according to Standards EN ISO 14120, EN ISO 13857, EN 349 and UNI EN ISO 12100 with captive screws.
- Protection networks where applicable or required (not necessary if the fan is connected to the supply or suction line).
- Protective casing for rotating parts (motor cooling fan, transmission belts, etc).



If not present, do not start the fan and immediately inform HDF srl

The electrical part connection must be present (not charged to HDF):

- emergency stop mushroom-head button on the electric panel.
- main switch, on the electric panel of the Machine



2.7 **Noise level**



The Fan does not require the constant presence of an operator during operation.

The Fan is noisy.

The noise level may exceed 80 dB(A), therefore you are advised to use earmuffs any exposure to noise, either slight or continuous.

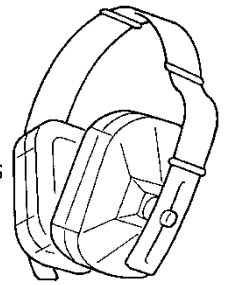

2.8 **Intended use**

After the technical inspection performed by the technical department of **HDF S.r.l** the scope of the Fan is as follows:

Produce a stream of air, gases or vapours by increasing its pressure, with variable flow rate and head depending on the model.

Vapours or gases shall conform to the characteristics of the model.



Any application other than described above must be assessed by **HDF** technical department.

2.9 **Unintended use**

The fan is not suitable for use at speeds and temperatures that exceed those for which it was designed and under conditions other than those indicated in the technical catalogues.

These fans are intended for use by professional users only.

2.10 **What you should always do!**

These points should be considered an integral part of the previous points.

Correct use of the Fan allows you to fully avail of its performance, which the same is designed to output in complete safety.

Such performance is only guaranteed by strictly complying with the instructions outlined below and therefore:

***ALWAYS:**

- use the Fan only and exclusively with the fluid for which it was designed;
- correctly fit the fixing accessories of the Fan;
- during the lifting and handling phases, use only complete and undamaged lifting cables for lifting and handling;
- handle the lifting unit slowly and safely;
- work in the best lighting and visibility conditions in the load handling area;
- operate outside the handling radius of the load being lifted;
- avoid as much as possible to control the vehicle in jog mode in quick sequence, use the "low" speed option, if available;
- avoid sudden movements, slopes and high speeds (>8m/min);
- wait before you lift the load until the lifting cables are stretched;
- check the various parts of the Fan are intact and check for wear;
- follow the directions and instructions in the Installation, Use and Maintenance Manual;
- comply with the instructions outlined in the wiring diagrams attached for electrical maintenance;

- strictly follow the procedures in this Manual described for activation and disabling;
- check that performance complies with the intended service (work cycles, usage times);
- ensure that the Fan can operate under the ambient conditions stated in the offer.
- comply with the signs highlighted. Compliance with the above also has an accident-prevention function; these signs must always be perfectly legible;
- ensure adequate preservation (cleaning, lubrication) and maintenance of the Fan and all its parts;
- check the correct anchorage of the guards, the Fan, the mechanical and electrical limit switches;
- check that the stop/emergency buttons are working;
- check that the control panel is intact and working properly;
- cut power supply to the Fan in the event of inspection, repair, and routine maintenance interventions. Disable the transmission mechanically;
- for all operations, use the personal protective equipment (PPE) suitable for the activity to perform, in compliance with the safety standards at workplace;
- notify the Department Manager of any anomalies (faulty behaviour, suspected breakage, improper movements and irregular noise) and put the Fan out of service;
- respect the frequency of the maintenance and adjustment operations and fill out the maintenance record upon every intervention, also including any relevant comments;
- check the functional efficiency of the safety devices of the guards;
- check the correct anchorage of the guards;

2.11 **What you should never do!**

Unintended use, unpermitted use, foreseeable incorrect use.

Use of the Fan for manoeuvres which are not permitted, its improper use and lack of maintenance can lead to seriously dangerous risks to the health and safety of the Operator or the exposed people, as well as damage to the workplace and the functionality and intrinsic safety of the Fan itself.

The actions described below, which obviously cannot cover the entire range of potential cases of "bad use" of the Fan, are those "reasonably" foreseeable improper uses which are considered strictly forbidden and therefore:



DANGER! ***NEVER:**

- allow people to pass through the lifting and moving area of the Fan and its parts;
- try to lift parts of the Fan if they or the fan are unbalanced or if the lifting equipment is not correctly connected in relation to the centre of gravity of the load;
- put your hands in the vicinity of the lifting cables during lifting; put your hands in the areas of contact with the hook of the hoist during "tensioning";
- leave parts of the Fan suspended or unattended during lifting;
- swing the Fan or its parts during lifting and handling;
- change the driving direction suddenly during handling;
- never heat the frame of the Fan or its parts with a blowtorch or other heat sources;
- allow unqualified staff or people under 16 years of age to use the Fan;
- use the Fan if not physically-mentally suitable;
- weld the Fan, or carry out any welding filling operations;
- work in areas in which use of spark-proof parts is specified or in the presence of strong electromagnetic fields;
- change its functional/performance characteristics;
- carry out temporary repairs or resets not complying with the specifications in the Instructions Manual;
- change, decalibrate, tamper with the Fan;
- use non-original spare parts or parts not recommended by **HDF S.r.l.**;
- entrust maintenance and repair operations to staff not trained by **HDF S.r.l.**;

- abandon the Fan at the end of work without implementing the relevant safety procedures;
- use the Fan for services other than its intended use and avoid using it as a resting point for ladders or as a base to replace lamps, etc.;
- use its frame as a grounding for welders;
- use the Fan in potentially explosive atmospheres
- use the Fan in improper ambient conditions.
Respect the temperature range, from -10°C to +45°C, and the humidity range, from 30% to 80% (unless otherwise specified by **HDF S.r.l.**);
- carry out ordinary maintenance operations, inspections or repairs without having placed the Fan out of service and having activated the relevant safety procedure.
during the maintenance phases:
 - use unsuitable devices;
 - work without personal protective equipment;
 - work without locking the disconnect switch and use adequate lighting in the operating zone;
- clean with aggressive liquids or that can damage its parts;
- expose the Fan to the action of sprayed liquids;
- disconnect components.
- carry out cleaning operations with compressed air inside the electric box;
- grease the drive belts;
- disconnect pneumatic system components before closing the outlet and releasing the residual pressure.
- remove the guards completely or partially or loosen their fasteners
- keep the fan running with closet inlet/outlet for more than 15 minutes.

2.12 Final part

In the event of inhalation or contact with toxic substances, do as indicated in the safety data sheet for the substance: as quickly as possible INFORM A DOCTOR or THE COMPANY SPECIFICALLY TRAINED PERSONNEL (IF ANY).

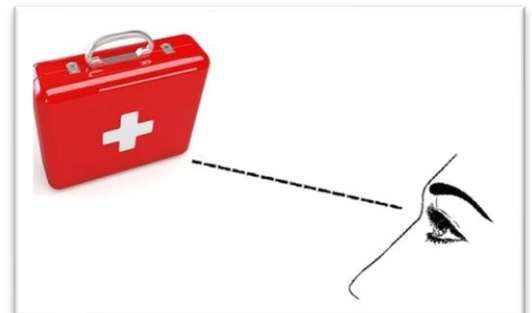

3 TECHNICAL DESCRIPTION AND SPECIFICATIONS

3.1 Technical description

The industrial fan (hereinafter referred to as fan) is a turbomachine that receives mechanical energy and utilises it by means of an impeller fitted with blades to maintain a continuous flow of air or other gas passing through it and whose work per unit mass does not exceed 25 kJ/kg (UNI EN ISO 13349).

Radial flow fan (centrifugal): fan in which the air enters the impeller with an essentially axial direction and leaves it in a direction perpendicular to this axis.

The blades:

- **negative** where the fluid is processed by the back, convex side;
- **positive** where the fluid is processed by the front, concave side; radial or straight where the fluid is processed either with the back or the front side of the blade if there are no stiffeners on either side.

As indicated in standard UNI-ISO 13349 - 2002:

- definition of arrangements,
- type of impellers,
- designation of the direction of rotation
- fan outlet position.

3.2 Technical data nomenclature

The essential characteristics of a fan are as follows:

- **Volume flow rate:** the volume of fluid that passes through the fan per unit time, per second (m^3/s), per minute (m^3/min), per hour (m^3/h);
- **Static pressure:** the energy provided by the impeller to overcome the resistance to the fluid passing through the fan (measured in mm w.c. or Pascal = Pa);
- **Dynamic pressure:** the energy of the fluid resulting from the speed induced by the impeller as it exits through the fan outlet (measured in mm w.c. or Pa);
- **Total pressure:** the algebraic sum of the static and dynamic pressure (measured in mm w.c. or Pa);
- **Speed of rotation:** the speed of the impeller, measured in revolutions per minute (RPM);
- **Efficiency:** percentage ratio between the energy transmitted by the fan to the fluid and the energy provided by the motor to the impeller; it depends on the shape of the impeller;
- **Power consumption:** the power required (supplied by the motor) by the fan to operate, measured in kW;
- **Rated motor power:** the nominal power that the motor can provide; it is always greater than the fan power consumption and is measured in kW;
- **Sound pressure level:** energy that propagates in the ear canal and causes the eardrum to vibrate; in other words, it is the noise level of the fan and is measured in dB(A) (decibel) according to scale A (scale that allows assessing the impact of the noise on the human ear in relation to the frequency of the same);
- **Sound power:** the rate at which sound energy is emitted; it is an intrinsic and invariant characteristic of a noise source.

The sound power level is expressed in Watts.

3.3.A. Type of impellers for centrifugal fan

1) - Backward-curved blade series **B**

2) - Aerofoil blade series **A**

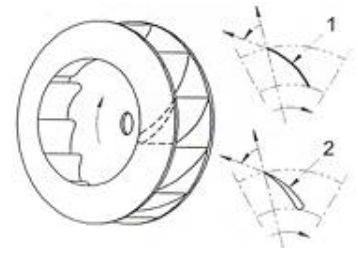

3) - Backward-inclined blade series **C**

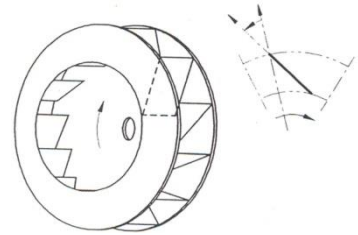

4) - Radial blade series **D / E**

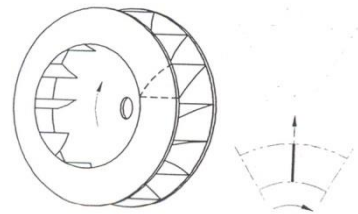

3.3.B Type of impeller for axial fan

1) - reversible (bidirectional)

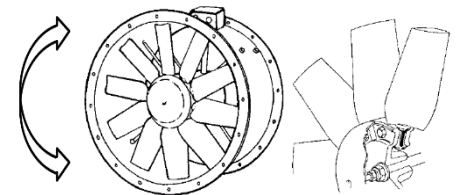

2) – unidirectional (airfoil or saber)

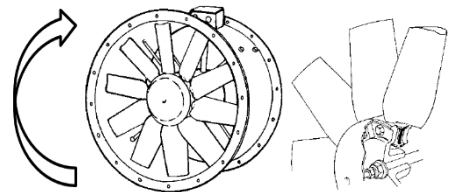

3) – radial

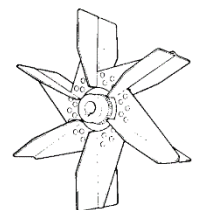

Note: always check the direction of rotation indicated on the fan

3.4 Arrangements

Arrangement 4

Single-inlet fan for direct drive.

Impeller overhung on motor shaft. Motor supported by base

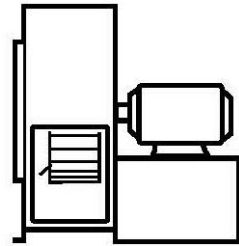

Arrangement 5

Single-inlet fan for direct drive.

Impeller overhung on motor shaft. Flanged motor attached to fan casing. Support feet welded to the fan casing.

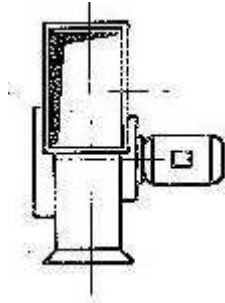

Arrangement 7

For belt or coupling drive. One bearing per side, supported by the fan casing.

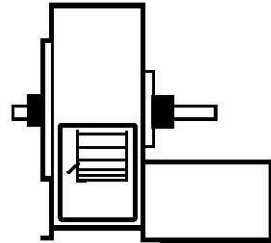

Arrangement 8

For belt or coupling drive. One bearing per side, supported by the fan casing. Two bearings per pedestal, with extended base for the prime mover.

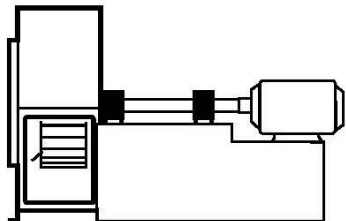

Arrangement 9

Single-inlet fan for belt drive. Two bearings per pedestal, with the motor mounted on the outside of the bearing pedestal

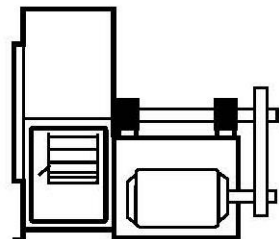

Arrangement 10

Single-inlet fan for belt drive. Two bearings per pedestal, with the motor inside the bearing pedestal

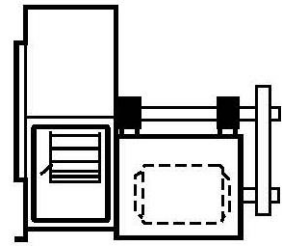

Arrangement 12

Single-inlet fan for belt drive.
Two bearings per pedestal, with the fan and motor supported by a common baseplate.

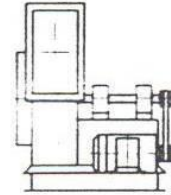

Arrangement 13

Single-inlet fan for belt drive.
Two bearings per pedestal, with the motor fixed underneath the pedestal.

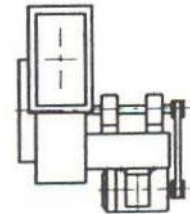

Note: other executions can be performed. This does not change the requirements and/or the indications included in this manual.

3.5 Discharge position (fan outlet position)

Centrifugal fans are installed according to 16 discharge positions (8 clockwise RD and 8 counter clockwise LG).

The direction of rotation is determined from the drive (motor) side.

Direction of rotation

LG Rotation

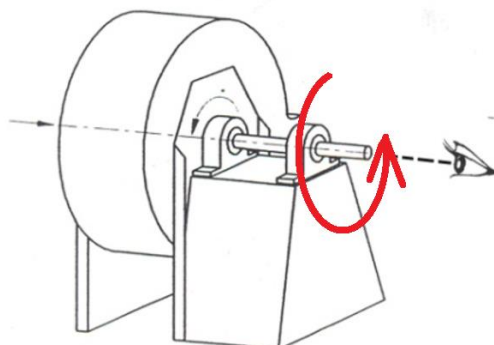

RD Rotation

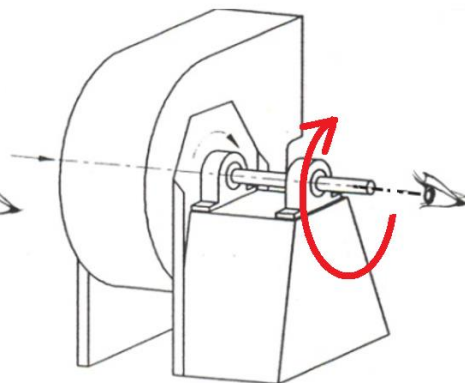

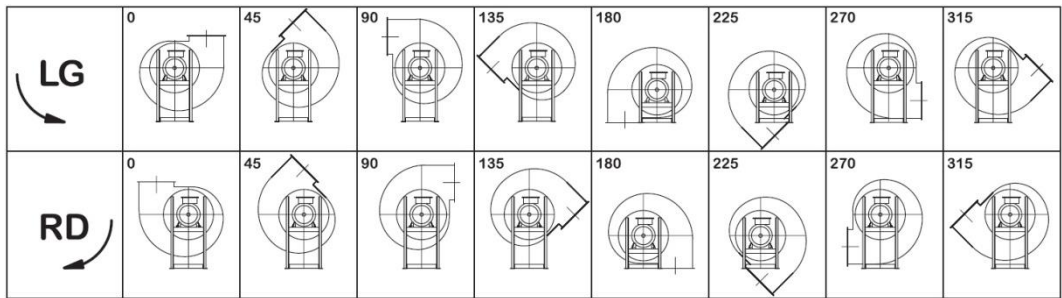

The discharge positions RD, LG 180 and 225 are possible only after making adequate adjustments

In the case of indirect drive arrangements, standard motor positions shall be adopted

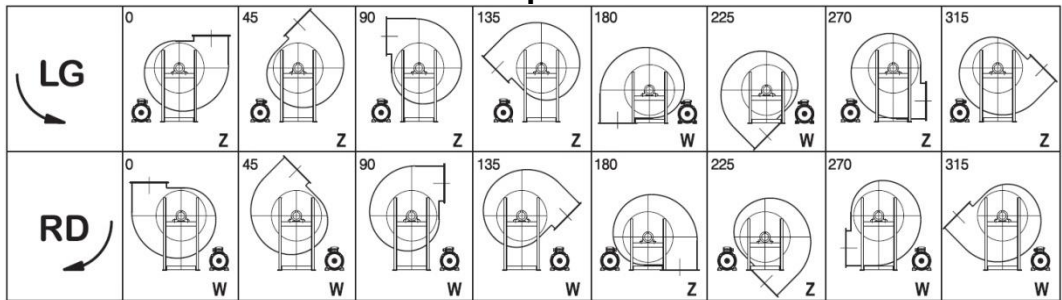

Axial fans are mounted in the same way as centrifugal fans, taking into account that the air flow is always axial
 The direction of rotation is defined for an observer on the side of the transmission (motor).

Flow A : motor - impeller

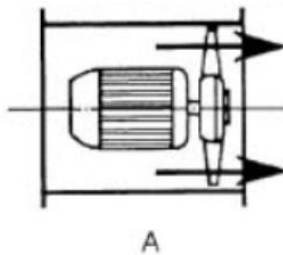

Flow B : impeller - motor

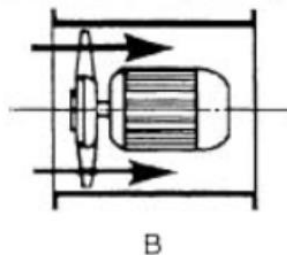

4 **LIFTING AND INSTALLATION INSTRUCTIONS**



WARNING

DANGER OF CRUSHING, KNOCKING, ABRASION AND CUTTING

The staff responsible for Fan handling must have read the Safety Provisions at the beginning of this Manual (Chapter 2), must wear overalls, gloves, safety footwear and a helmet.



ATTENTION

THE CENTRE OF GRAVITY OF THE FAN IS LOCATED AT THE CENTRE OF THE FRAME. THEREFORE, THE FAN IS BALANCED



4.1 Foreword



Upon package delivery, the staff in charge with handling must follow the instructions outlined in this Chapter, step by step.

The HDF technician (where present) is the person who dismantled or assisted the dismantling process in the factory after testing and is the contact person and the person who will assemble the Fan.

The instructions in the entire Chapter 4 are used as a memo if handling of the Fan, unpacking and handling of parts of the Fan is carried out without the supervision of the Technician in question.

Before proceeding with the positioning of the Fan, ensure that the support surface and all the connections comply with the specifications provided beforehand and with the civil works' layout. A copy of these specifications is given in Chapter 8 "Diagrams and Attachments".

Since you may access parts at height during assembly, you should have a suitable and safe ladder

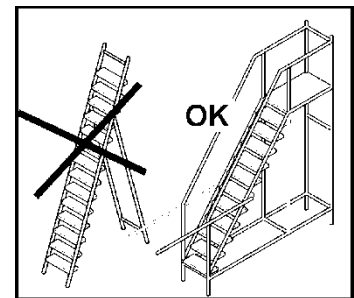

Before handling the machine, the operator in charge with transport must ensure that **THERE IS NO ONE NEAR THE PACKAGE.**

Unit lifting, handling and unpacking operations must be exclusively entrusted to staff who is expert in this type of operations (crane operators).

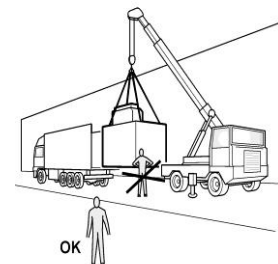

WARNING

Lift the fans with due care and caution during transport, paying utmost attention to protect the impeller and the shaft against shocks and collisions using wood or rags.

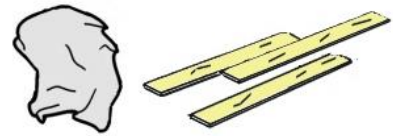

ATTENTION DANGER OF FALLING AND/OR TRIPPING AND CRUSHING

Cordon off, or in any way, prevent access to staff not unauthorised to carry out handling operations or those unaware of the dangers related to this phase.

DO NOT REMOVE THE BARRIERS UNTIL THE FAN POSITIONING AND FIXING OPERATIONS ARE COMPLETED.



WARNING DANGER OF CRUSHING

The various parts are tied and spaced with wood shims inside the packing case, for transport reasons.

These ties (iron wires and supports) and shims must not be removed when taking off the lid of the packing cases. **There is a danger of crushing due to moved loads.**

These ties are to be removed when picking up the component. For this reason, the person in charge of picking up and slinging the components must wear safety footwear, protective gloves and a helmet and must proceed with due care.

The Fan is intended for use in industrial environments.

The workplaces must be equipped with devices that provide adequate artificial lighting to ensure the safety and health of the Operators.

Workplace lighting must comply with the Laws in force in the Country where the Fan is installed and must be even and ensure good visibility from every point, without causing dangerous glare effects.

The lighting must allow for the safe execution of the maintenance operations covered in this Manual.

The floor must be level and able to support the Machine (especially if it is not installed on the ground floor).

There must be sufficient space for maintenance (minimum 1 meter).

The Fan must be installed according to the layout in Chapter 8 "Diagrams and Attachments".

WARNING

The work area must always be kept clear so that **NOTHING AND NOBODY** interferes with the free movement of the operator.

In the event of an emergency, immediate access must be guaranteed to the control devices of the Fan by the responsible staff.

Access to the work area is forbidden to those not directly responsible for Fan operation.

This restriction is necessary to avoid danger due to lack of attention or negligence when performing tasks.

The operator should therefore always keep the work area clear of any Equipment and deny access to unauthorised persons in order to have the ideal safety conditions to work with the Fan.

IF THESE CONDITIONS ARE NOT MET, PROVIDE FOR THEM BEFORE INSTALLING THE FAN.

Since the impeller has been balanced at the HDF Factory, it must be handled with due care, following the instructions below:

- never lift the impeller by its blades or by its cone

- do not roll the impeller if you can move it with cables.
If you have to roll the impeller, place it on a smooth surface and proceed with due care
- never place the impeller on the ground with its weight leaning on the shaft; place wood shims beneath the shaft close to the impeller (any shaft deformation will cause vibrations).
- Coated impellers must be handled with due care and should never be moved by rolling.

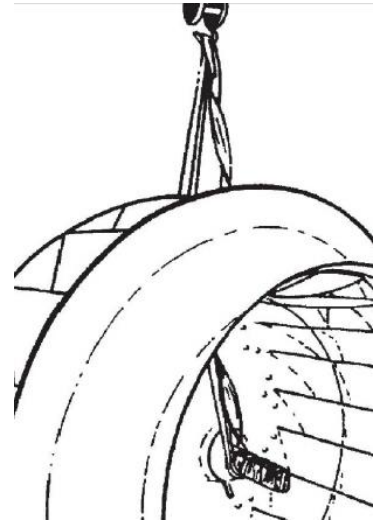

Road transport

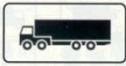

Road transport takes place by truck.

Depending on the requirements, the various parts of the Fan can be:

- fixed to a load bearing platform (or crate). The various parts can also be covered with cellophane, shrink wrap or bubble wrap to protect them from atmospheric agents.
- fixed on wooden or metal feet. The various parts can also be covered with cellophane, shrink wrap or bubble wrap to protect them from atmospheric agents.



Air or sea transport

For this type of transport, the Fan is fixed to a load bearing platform or crate. Can be used heat-sealed bags with hygroscopic substances that comply with the Standards in force.



The Customer must dispose of the packaging in compliance with the Standards in force in his Country (refer to Chapter 10 "Dismantling and Disposal").

4.2 Handling of the packed Fan and its parts

The Fan and its parts may be shipped in a packing case, a crate or on a pallet.

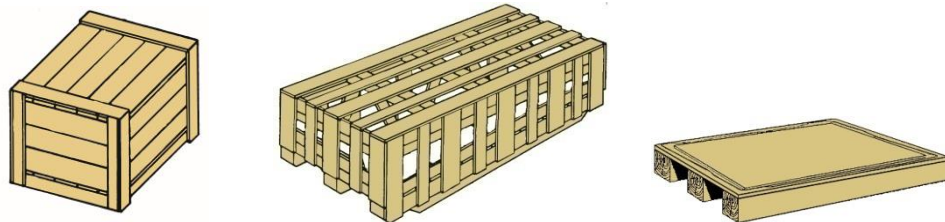

Whatever the case, the Fan is always delivered assembled in a single pack



NOTE
IF THE COMPONENTS ARE NOT TO BE UNPACKED IMMEDIATELY UPON RECEIPT,
STORE THEM IN A DRY, COVERED ENVIRONMENT WITHOUT REMOVING THEIR
PACKAGING

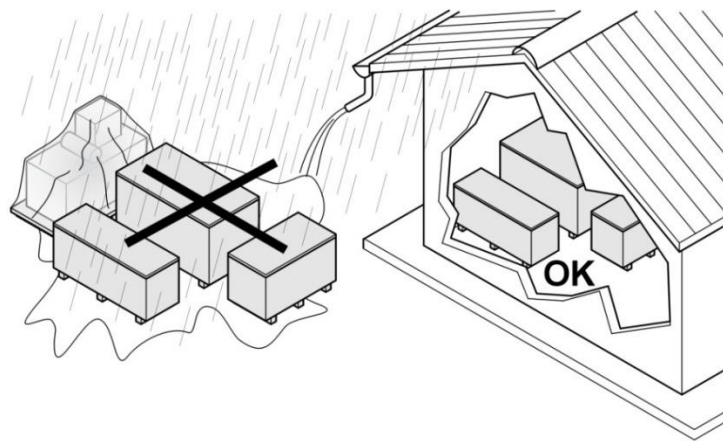

For handling:

- of packing cases and pallets with a forklift truck > section 4.2.1;
- of packing cases and pallets with overhead crane and cables > section 4.2.2.

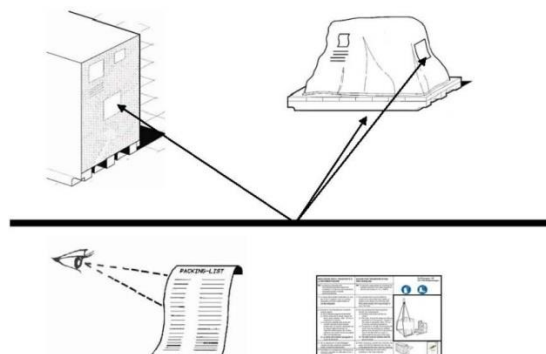

On the outside of the packaging are specified all the instructions necessary for handling as well as the name of the Customer, order, gross and net weight.

4.2.1 Handling of packing cases and pallets with a forklift truck

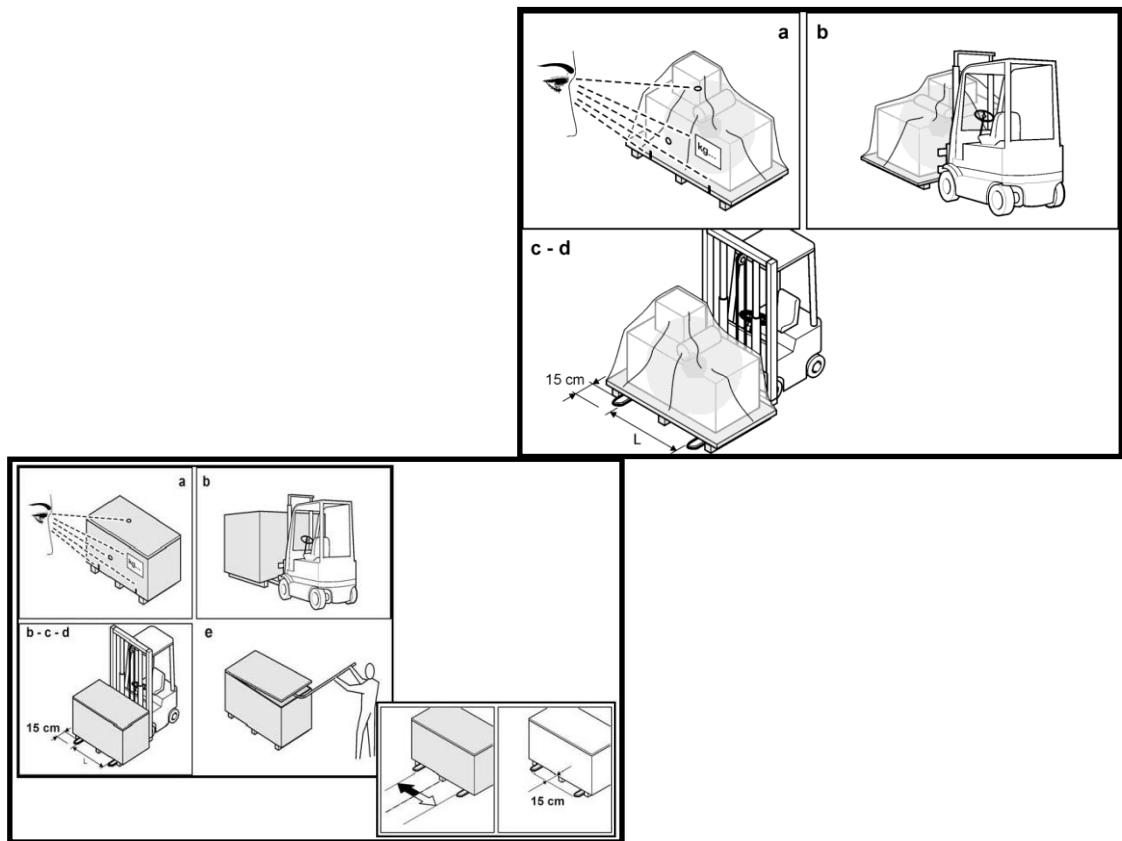

- Follow the indications on the packing case or on the pallet (especially the position of forks and centre of gravity): be reminded that the position of the forks is the widest possible (a);
- use a forklift truck of suitable capacity; the forks must protrude out of the packing case or pallet by at least 15 cm. (b);
- slowly move the packing case or the pallet, at minimum height from the ground (max. 20 cm) supported by an assistant if view is obstructed (c);
- lay it gently on the ground (d);
- to open the packing case, use an appropriate mean (such as a crowbar); start from the cover (e).

4.2.2 Handling of packing cases and pallets with overhead crane and cables

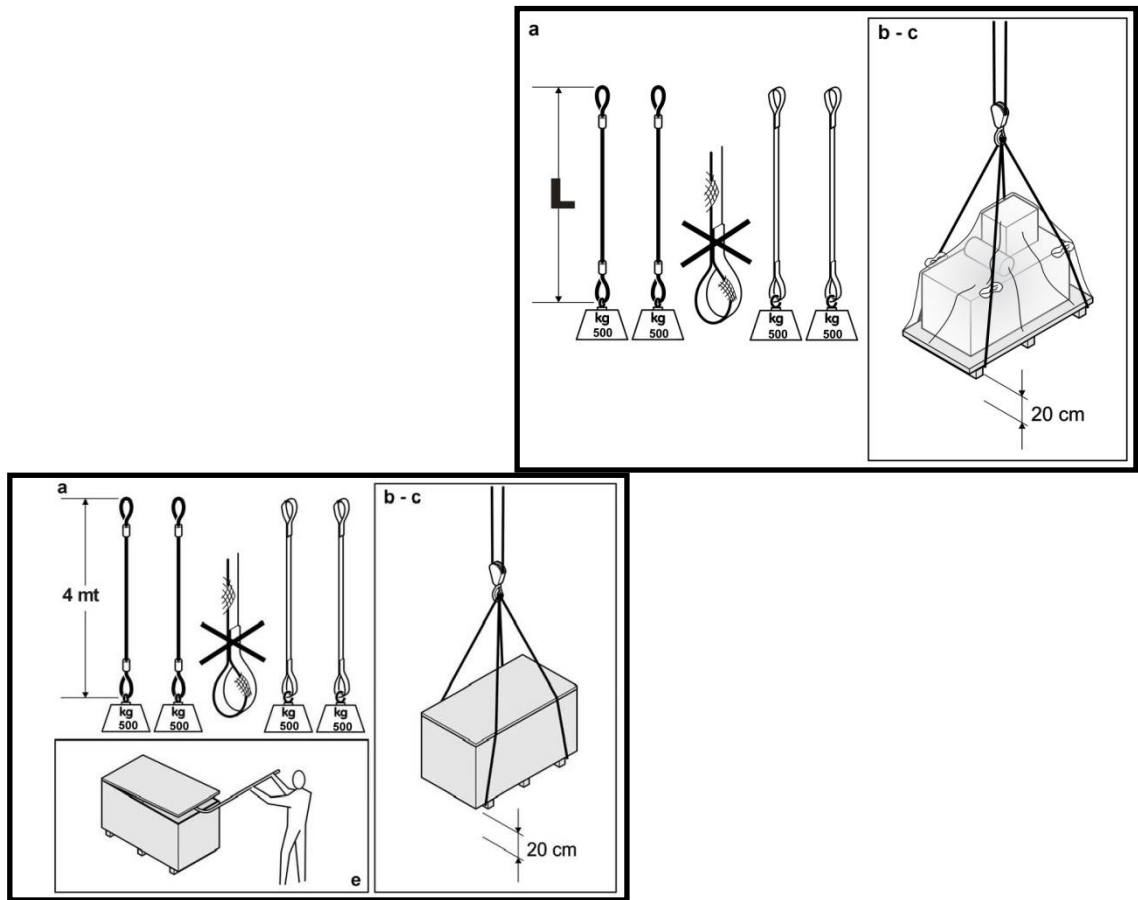

- Take two cables or straps with minimum length 4 m and minimum capacity adequate for the load to be lifted, with eyelets at the ends in good condition (a);
- harness the packing case or the pallet by following the indications on it (position of the cables, centre of gravity and weight) (b);
- slowly move the packing case or the pallet, at minimum height from the ground (max. 20 cm) supported by an assistant if view is obstructed (c);
- lay it gently on the ground;
- to open the packing case, use an appropriate mean (such as a crowbar); start from the cover (e).

4.2.3 Handling from a container

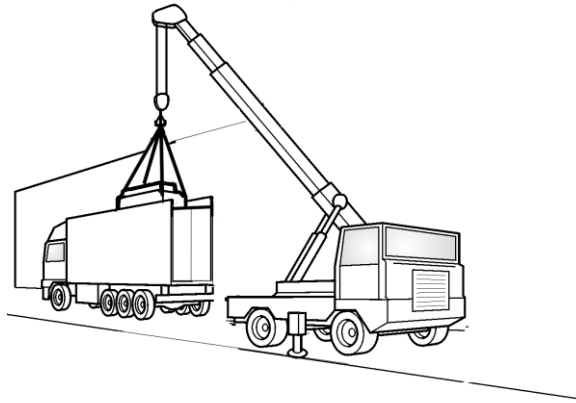

Once the container is prepared and opened, handle the Machine as indicated in paragraph "4.3 HANDLING OF THE UNPACKED MACHINE".

4.3 Unpacking

Unpack carefully using a tool (such as a crowbar) starting from the cover

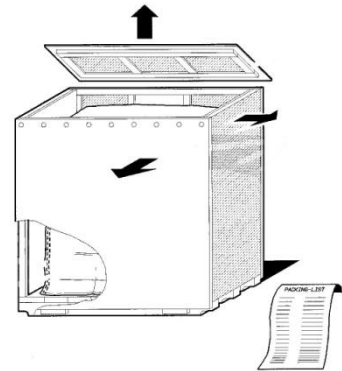

Remove the side walls.

For handling on site, use special carts.



WARNING

The carts should be positioned next to the uprights, NEVER ONLY ON THE CROSSBARS.

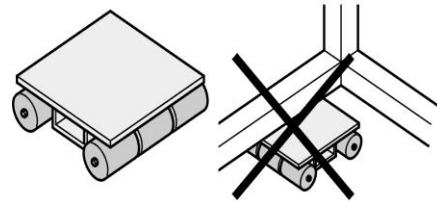

Remove the first cover in heat-sealing material plus barrier. Then remove the polyethylene cover.

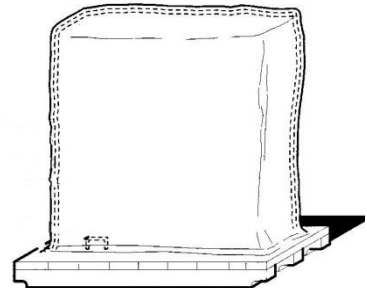

Check if the content of the package has been damaged during transport.

If so, immediately notify **HDF S.r.l.** or its Representative.

Draw up a list of components in the package and compare it with the packinglist.

In case of missing pieces or inconsistencies, please notify immediately **HDF S.r.l.** or his representative.

In case of missing pieces or inconsistencies, please notify immediately **HDF S.r.l.** or his representative.

Loosen and remove the screws of the locking brackets.

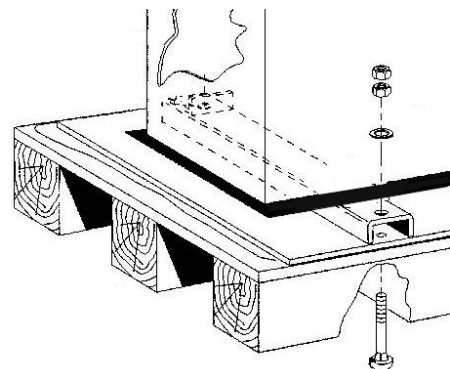

HDF S.r.l. RECOMMENDS, IN CASE THE MACHINE PARTS ARE TO BE PACKED BACK, TO STORE IN A DRY PLACE THE ENTIRE STRUCTURE OF THE PACKAGE AND ITS LOCKING COMPONENTS

4.4 Storage

If the Fan parts, still packed, are to remain unused for a long period, HDF recommends you store them in a dry and covered place, at temperatures between 5°C and 35°C.
Air humidity 75%.

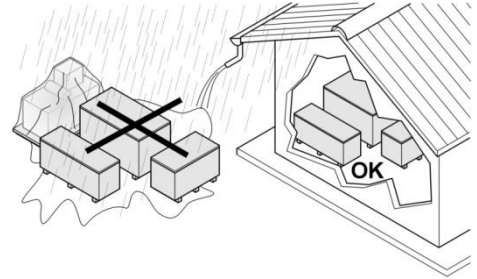

Do not place other packs on top of the stored materials

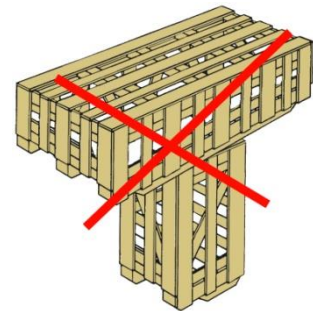

If the Fan has already been unpacked and assembled, so that it becomes extremely difficult to protect it with the packaging, HDF recommends to always store it in a dry place on a bench or on the base of the packaging.

Make sure all metal parts, in particular those external, are protected by a thin layer of oil SAE 46-SAE 68.
Cover the entire assembly with a cloth, that must allow residual internal moisture to evaporate.

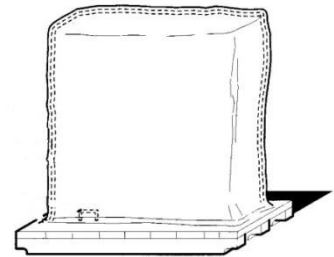

If the machine is not installed immediately upon receipt and is fitted with antifriction bearings, rotate the shaft of the fan manually or in a similar manner for several turns, once every 2 or 3 weeks.

This way, the grease inside the bearings will cover any less protected parts of the bearing, also preventing condensation.

Lock the impeller to prevent any accidental rotation due to air draughts

If the Fan is fitted with drive belts, we recommend reducing the belt tension by slightly loosening the turnbuckles.

The belts must be tensioned properly shortly before starting the machine.

Periodically, check the condition of the parts to avoid surface oxidation.

After long periods of inactivity, the machine must be commissioned by **HDF S.r.l.** technical staff or by technical staff authorised by **HDF S.r.l.**, ensuring that:

- the conditions and characteristics of the Fan before storage have been kept unchanged;
- there are no signs of corrosion on the frames;
- there are no signs of breakage due to improper storage;
- the electrical connections are efficient and there are no damaged cables;
- the pneumatic connections are efficient and there are no broken pipes;
- that all safety devices installed, tested manually are efficient.



If necessary, contact **HDF S.r.l.**

4.5 *Disposing of the package*

The disposal of waste materials must be made in compliance with the regulations in force in the Country of use, taking into account the nature of the materials:
straps, nails and metal parts;
wood and plywood planks;
plastic materials (protective film and barrier bag).



DO NOT DISPOSE OF THE PACKAGING IN THE ENVIRONMENT.

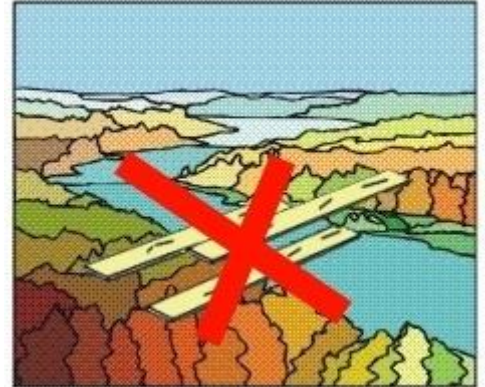

4.6 *Handling of the unpacked Fan*

Once you have unpacked the various parts, follow the indications below.



WARNING
DANGER OF SUSPENDED LOADS
BE VERY CAREFUL.



WARNING
Handling must be performed according to the specifications in this Chapter only; never harness the various elements on their protruding parts.

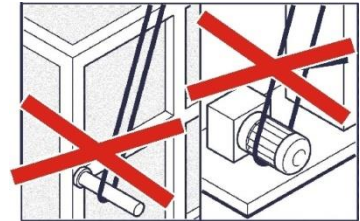

For the handling operations, you can use a forklift truck, an overhead crane or a crane

Handling with a forklift truck

When handling the machine with a forklift, always comply with the following principles:

- the forklift must have a capacity suitable for the load to be transported;
- observe the centre of gravity;
- observe the input position of the forks;
- if the position of the forks is not indicated, keep the distance between them as great as possible;
- the forks must be longer than the body to move and protrude by at least 10 cm.;
- handling must be done at minimum height above the ground (max. 20 cm);
- if visibility is hampered, get help from an assistant;
- lay it gently on the ground.

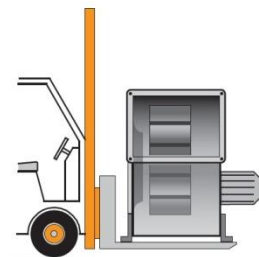



Handling with a crane or overhead crane

For lifting and handling, use only one equalising bar.

Take four cables or straps with minimum length 4 m and minimum capacity of 12000 Kg. each, with eyelets at the ends in good condition.

When lifting and moving the parts sideways, be careful to avoid sudden movements and excessive oscillations.

Proceed as follows:

- first, insert the hooks of the cables in the special eyebolts and make sure the pawl prevents them from coming out;
- slowly move the machine to the lowest possible height above the ground (max 20 cm), assisted by another operator if view is obstructed;
- gently place the load on the ground close to the intended installation location;
- after completing the assembly operations, remove the eyebolts (where applicable) and keep them for future use.

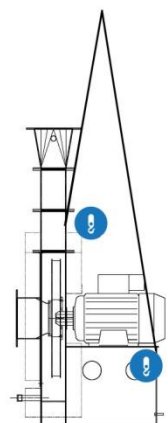
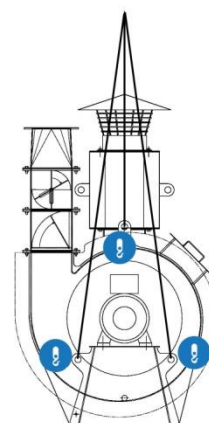
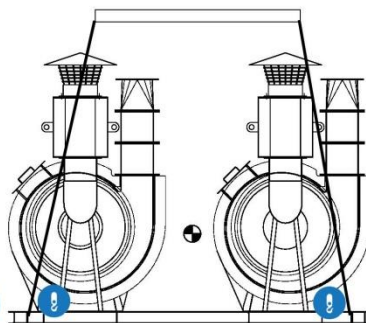
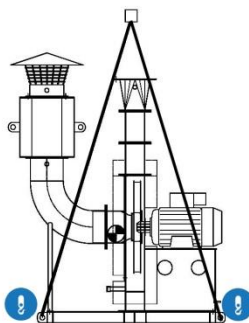
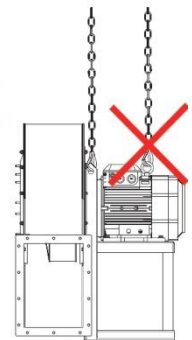
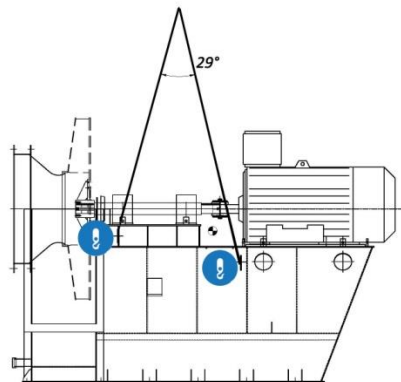
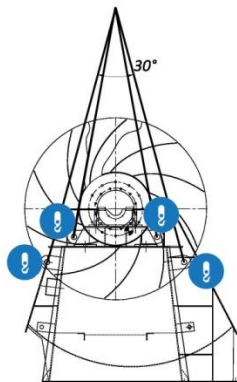
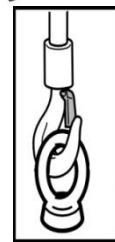

4.7 Handling of loose or light parts

The lighter parts refer to:

- boxes containing small parts;
- technical documentation;
- parts of the pneumatic system;
- cables and electrical connectors;
- other small accessories

Due to their nature and their small size, all lightweight parts are placed on the base in separate packing cases, some of them tied up to the fan, others simply placed next to it.

This is why before handling the fan, YOU SHOULD REMOVE the lightweight parts first.

Place them close to the place of installation, so that they do not fall and do not impede the movement of the other parts.

4.8 Foundations

A rigid and level foundation is essential for the stability of the fan and prevents the formation of vibrations.

The most suitable foundations for fans, motors, etc. are those made of reinforced concrete. Suitably reinforced steel frames can also be used.

4.8.1 Reinforced concrete foundation

Make sure that the location where the parts are to be installed possesses the following characteristics

Reinforced concrete foundations must be sized considering the static and dynamic loads of the fans.

The fan must be secured to its base by means of foundation bolts or steel or chemical plugs, as indicated in the technical drawings supplied with the machine.

TIRANTI DI FONDAZIONE											T.00009	
TIRANTE	ROSETTA	DADI (3)		A	B	C	D	E	F	SULLIPIRO	CARICO Max Kg	
Ø (1)	Ø ₁ x Ø ₂ (2)	N° pezzi	Ø							TRANTE	Totale	Trazione
M12	13 x 24	2	M 12	60	300	145	445	60	370	300	600	
M14	15 x 28	2	M 14	80	60	350	180	510	70	645	400	800
M18	17 x 30	2	M 18	90	70	400	175	575	80	710	500	1100
M18	19 x 34	2	M 18	100	70	450	190	640	90	790	850	1300
M20	21 x 37	2	M 20	120	75	500	200	700	110	880	850	1700
M22	23 x 39	2	M 22	140	80	550	215	675	110	965	1050	2200
M24	25 x 44	2	M 24	150	80	600	230	830	120	1045	1200	2600
M27	28 x 50	2	M 27	170	90	680	245	925	130	1160	1500	3300
M30	31 x 56	2	M 30	180	95	750	270	1020	140	1290	2000	4300
M33	34 x 60	2	M 33	210	100	830	285	1115	150	1410	2200	5100
M36	37 x 66	2	M 36	230	105	900	310	1210	160	1480	2500	6000

Note:
 1) Tirante "Tranea" S.B. - ISO 8988
 Carico di rottura minimo $B_{min} = 500 \text{ N/mm}^2$
 Carico unitario di ancoramento minimo $B_{min} = 400 \text{ N/mm}^2$
 2) Rosetta "Dati" S - ISO 8884
 Carico di rottura minimo $B_{min} = 400 \text{ N/mm}^2$
 Carico unitario di ancoramento minimo $B_{min} = 200 \text{ N/mm}^2$

The foundation bolts must be cemented into metal tubes; the diameter of said tubes must be two and a half times larger than the diameter of the bolt to ensure better adjustment during concrete consolidation (between 24 and 48 hours depending on the case).

The number of foundation bolts or chemical plugs must match the number of holes in the base of the fan.

Leave a small space of about 10÷15 mm between the concrete surface of the foundation and the bottom wire of the metal base that will be filled with shims and levelling materials.

4.8.2 Foundation with steel frames

The fan fixture must be rigid enough to block any vibrations to the fan.

The first natural frequency at any point on the frame should be 50% greater than the frequency corresponding to the speed of the fan and of the motor.

The frame must be reinforced with adequate stiffeners to ensure and maintain its proper alignment. Suitable anti-vibration mountings must be bolted to the frame before mounting the fan.

4.8.3 Anti-vibration mountings

If the fans are fitted with anti-vibration mountings, they must be installed on a rigid, stable surface. Before locking the bolts ensure that the compression arrow is identical for all the mountings.



ATTENTION!

The Engineer and the Manufacturer are responsible for the proper sizing and selection of the materials used to build the foundation.

4.9 Inlet and outlet ducts

After installing the fan, you can connect the inlet and outlet ducts.



The connections should not force the position of the fan because any deformation of the casing may cause the fixed and mobile inlet cones to touch, may result in misalignments, etc.

The ducts must be connected in such a way as to prevent any static loads, vibrations and thermal growths from affecting the fan.

To meet this requirement, particularly when the temperature of the conveyed fluid exceeds 100° C, you might have to fit the inlet and outlet ducts with an expansion joint made of a suitable material (evaluation to be conducted upon express request, with adequate analysis of temperatures).

These joints must be installed between the fan and the duct, upstream of any inlet dampers or downstream of any outlet dampers (where applicable).

In particular, the fan must be fitted with this kind of flexible connections if installed on anti-vibration mountings.

When installing the flexible connections:

- be careful not to damage the flexible parts;
- interpose a suitable ceramic fibre gasket \varnothing 4 mm between the coupling flanges (unless otherwise specified in the technical drawings attached to the supply).
- use bolts, nuts, washers, etc. of a suitable diameter and with tightening torques as listed in the technical drawings supplied with the machine.



ATTENTION!

Any openings not connected to ducts must be provided with adequate protection grids in compliance with standard ISO – 12499/1999.

According to standard ISO – 5801/5802 the fans:

- with installation type "A" must be equipped with protection grids on both openings.
- with installation type "B" must be equipped with protection grids on the inlet.
- with installation type "C" must be equipped with protection grids on the outlet.



According to standard ISO – 5801/5802, for the openings connected to ducts, in case of fans with installation type "B", "C", "D", special precautions must be taken to prevent the ingress of foreign bodies inside the fan through the conveyed fluid.

In order to ensure consistent fan performance, the ducts must be connected in such a way that the fluid flow is as even as possible, avoiding the formation of vortices.

4.10 Positioning and installation of the Fan



WARNING

DANGER OF SUSPENDED LOADS, CRUSHING, IMPACT, ABRASION AND CUTTING

The staff responsible for Fan positioning and installation must have read the Safety Provisions at the beginning of this Manual (Chapter 2), must wear overalls, gloves, safety footwear and a helmet.



The fan is usually supplied completely assembled but since it can also be supplied disassembled and during its service life you might have to replace different components, this section described the assembly procedure for each component of the fan.

All fans undergo inspections before shipment to check the correct assembly and the conditions of all the components and accessories installed; therefore, if the fan is supplied already assembled, make sure it does not present any visible signs of damage due to transport and/or handling and proceed with its installation.

Should you notice any signs of damage, suspend the installation and follow the instructions in par. 2.2

If the fan was supplied disassembled, check the condition of the various parts and/or accessories and proceed with their assembly following the procedures below.

Said procedures must be followed whenever you need to disassemble and re-assemble the fan or parts of it (for maintenance, components' replacement, etc.).

4.10.1 Installation methods (UNI EN ISO 13349)

Fan installation types according to the arrangement of the ducts:

Installation type A: installation with free inlet and free outlet. To be provided with suitable inlet and outlet

guards (protection grids). The inlet protection grid can be found in the catalogue and in the price list (for sizes refer to the catalogue). The outlet protection grid is neither in the catalogue nor in the price list (available only on request).

Installation type B: installation with free inlet and ducted outlet. To be provided with a suitable inlet guard (protection grid). The inlet protection grid can be found in the catalogue and in the price list (for sizes refer to the catalogue).



Installation type C: installation with ducted inlet and free outlet. To be provided with a suitable guard (protection grid).

Installation type D: installation with ducted inlet and ducted outlet. Does not require guard (protection grid). To be provided with flexible connections (model supplied by HDF) to avoid any misalignments and to prevent the propagation of vibrations. The flexible connection must be selected based on 2 factors: temperature and type of fluid.

4.10.2 Checks before the assembly

- 1 Make sure that the fan has not been damaged during transport.
- 2 Make sure that the casing and the impeller match the type of fan requested.
- 3 For models supplied assembled, check the discharge position of the casing (0° , 45° , 90° ...) and the direction of rotation of the impeller (LG = counter clockwise or RD = clockwise) identified by an adhesive label (arrow) applied on its outside.

N.B. The correct discharge position of the casing must be checked referring to the "discharge position table" in the "catalogues".

 LG	0	45	90	135	180	225	270	315
	 RD	0	45	90	135	180	225	270
	H1			H2			H	

The direction of rotation of the impeller must be identified from the side of the electric motor. For axial fans, check the direction of rotation and orientation: motor - revolutions or motor impeller

- 4 Make sure that the electric motor (to be provided by the customer) to be installed on the fan has the same technical, construction and performance characteristics as those specified in the order.
- 5 Make sure that the electric motor mounting holes on the pedestal base match the electric motor mounting holes on the fan (see the manual of the electric motor attached).
- 6 Make sure that the fixing bolts of the electric motor are tightened to the fan.
- 7 Make sure that the diameter of the hole of the impeller matches the electric motor shaft and that the diameter of the shaft matches that of the coupling/pulley.
- 8 Make sure the height of the electric motor axis (h) matches the height of the pedestal hole on the top base of the pedestal.

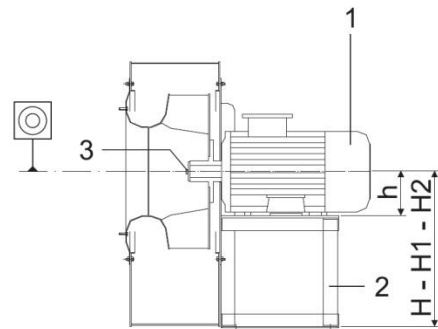

- 9 Make sure that the value H or H1 or H2 is the required one.
- 10 If the fan complies with the ATEX Directive, check the characteristics in Chap. 12.

4.10.3 Preliminary operations before fan fixing

Make sure that the location where the parts are to be installed possesses the following characteristics:

- the artificial lighting of the premises must comply with the legislation in force in the Country where the Fan is installed. Must ensure good visibility in every corner of the room; must not create dangerous glare effects. Moreover, lighting must allow for the safe execution of the maintenance operations covered in this Manual;

- there must be a minimum clearance of 1.5 m around the machine for maintenance, passage of forklift trucks;
- the Customer is responsible for the verification and/or sizing of the supporting structure.

IF THESE CONDITIONS ARE NOT MET, PROVIDE FOR THEM BEFORE INSTALLING THE FAN.

NOTE



The Fan must be fixed to the Machine ONLY:

- by **HDF S.r.l.** staff (if specified in the contract);
- by the Customer's Technical staff trained for this type of activity.



No other Technician is authorised to carry out assembly operations.

If necessary, clean the machined parts with an appropriate detergent.



4.11 *Indications for the connection to the machine*



**WARNING
GENERAL HAZARDS AND RISK OF
ELECTRIC SHOCK**

These operations must be carried out by a single professionally qualified Technician, NEVER BY MORE THAN ONE PERSON.

The Technician must have read and understood the Safety Provisions (Chapter 2) at the beginning of this Manual.

He also needs to ensure that, while performing the connections, no other person is present in the designated Fan area or its energy source areas.



**MAKE THE CONNECTIONS
REFERRING TO THE RELEVANT
DIAGRAMS.**

The connections must be performed following the procedure below, after assembling the Fan and fixing it to the Machine in its own stable position:

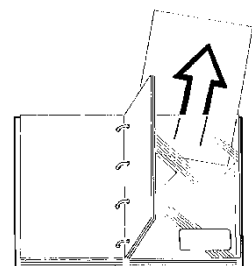

4.11.1 *Connection of the pneumatic equipment (air)*

Any pneumatic equipment installed on the fan must be connected following the instructions provided by the manufacturer of said equipment and attached to this Manual.

4.11.2 Connection of the motor and/or electrical equipment



Refer to the wiring diagrams of the Fan and/or electrical motor before making any connection and make sure that both motor and fan earthing bosses are connected to the main earthing system. Also check the efficiency of the earthing system and check the continuity of the protection circuit installed on the Fan



When making the electrical connections, please observe the safety standards in force and make sure the rating match the characteristics of the circuit to which the motor and/or the electrical equipment is to be connected. Make the connections following the instructions provided by the manufacturer of the motor and/or electrical equipment. After making the connections and tightening the nuts of the terminals, close the cover of the terminal box with the relevant gasket.



CAUTION!

If the fan is installed at a distance from the panel and/or control station, provide an omnipolar service switch next to the fan.

A copy of the instructions provided by the manufacturers of the motors and/or electrical equipment is attached to this Manual. If they are not attached, it is necessary to request or download them from the manufacturer's website.



4.11.3 Connection to the extraction system



IT IS THE RESPONSIBILITY OF THE USER TO PROVIDE FOR THE CONNECTION OF THE FAN TO THE EXTRACTION SYSTEM AVAILABLE AT THE PREMISES. HDF DISCLAIMS ANY LIABILITY FOR DAMAGES TO PEOPLE, ANIMALS AND PROPERTY.



THE FANS THAT COMPLY WITH THE ATEX DIRECTIVE 2014/34/UE MUST BE INSTALLED BY A QUALIFIED TECHNICIAN FOLLOWING THE APPLICABLE REGULATIONS IN FORCE.



CAUTION

Do not use air pipes (extensions) and transition pieces unsuitable or that do not comply with the regulations in force.

Do not commission the fan before connecting it correctly to the extraction system available at the site of installation.

Do not commission the fan if the extraction system in which it is to be installed has not been declared compliant with the provisions of the applied directive.

5. COMMISSIONING

5.1 First start-up and testing



Before shipment, the Fan undergoes a pre-testing at the **HDF S.r.L.** premises. This pre-testing phase includes all the adjustment and calibration operations required by the mechanical parts and the electrical devices

It is the responsibility of the **HDF** technician in collaboration with the Customer's technician to optimise the fan's performance for the operations specified in the order confirmation.



In standard version, the Fan is not equipped with a lighting system. The light level must ensure safe operation at all times.

If you need to perform maintenance operations in poorly illuminated areas, please use portable lighting systems paying attention to avoid any shadows that may reduce the visibility of the point concerned by the maintenance work or of the surrounding areas

For the first seals set up and maintenance please refers to the dedicated section at chapter 7 (Maintenance, cleaning and lubrication).

5.2 Preliminary checks



After assembling the Fan and all its parts and after making all necessary connections, the **installer** must proceed as follows before starting the fan:

- check the correct mechanical assembly of the Fan and all its parts, make sure that all the bolts are properly tightened, especially those of the impeller, of the motor and of the inspection door;
- check the correct balancing of the impeller;
- make sure the environment complies with the standards (in terms of lighting, temperature);
- make sure the provided power supply voltage is within $\pm 10\%$ of the nominal value;
- make sure the nominal line voltage is suitable for the operation of the Fan;
- make sure the safety devices work properly;
- turn the impeller by hand (if possible) to make sure that all parts can rotate freely;
- Make sure there are no foreign bodies inside the fan casing or ducts.
- If there are any dust, water or fluid residues inside the fan, have them removed;
- If the inlet and/or outlet are not connected to ducts, provide them with adequate protection grids.



CAUTION!

NEVER start the fan if there are any free, unprotected openings.

If the fan is not fitted with the necessary guards, the installed must provide them in compliance with standards UNI EN 14120:2015 and UNI EN 13857:2008.

For fans with belt drive delivered assembled, the alignment was performed at the HDF premises.

Before starting the fan, make sure that:

1. The pulleys are locked in their positions.
2. The key is secured in its seat.
3. Check the belts are correctly tightened.

Start the fan and check if its direction of rotation is correct.

Run the fan at full speed.

You should notice a kink in the belt on its slack side.

Adjust the turnbuckles

5.3 Start-up procedures

1. The start-up procedure must be carried out with the damper or the flow regulator (where applicable) completely closed to decrease the time and therefore the overload of the motor upon start-up.
2. Start the motor.
3. Check if the direction of rotation of the impeller is correct: if the impeller should rotate in the opposite direction, interchange the connections of two phases of the power supply line (for three-phase motors).
4. Check that the motor rotates in the correct direction of rotation according to the manufacturer's instructions.
5. Once the fan reaches the operating speed, open the dampers at least partially (where applicable) to prevent the overheating of the fan.

5.4 Checks during start-up

1. Check the motor absorption: the intensity of the current absorbed by the motor should not exceed, at full capacity, the value shown on the plate.
2. After making sure that the fan works properly, the checks during start-up should last at least eight hours.
3. During this period of time, you must check the vibration level frequently (at least once an hour).

6. USE AND OPERATION

6.1 Checks before switch-on



WARNING - GENERAL DANGER

Carefully read the Safety Provisions section at the beginning of this Manual (Chapter 2), paying particular attention to the function of the main switch and of the emergency buttons. In case of emergency, proceed as follows:



set the main switch on the electric panel to "OFF";
or press the EMERGENCY STOP button installed on the
Machine into which the fan is integrated.

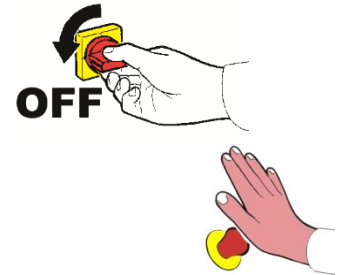

The operations to be carried out by the **HDF** Technician before start-up are as follows:

- make sure that you have all the manuals necessary for the correct use of the fan and its accessories and components (eg electric motor, actuator, sensors, etc);
- visual inspection of the area where the Fan is installed;
- make sure that the fan is correctly positioned;
- make sure there are no unauthorised persons in the vicinity of the fan;
- make sure that the safety devices are in good condition, correctly installed and working properly;
- Make sure that the bearings are lubricated;
- make sure the machine is level;
- make sure the bolts of the impeller, of the bearings and of the electric motor are tightened
- connect the system to the mains;
- check the direction of rotation of the fan impeller;
- make sure that all parts can rotate freely;
- make sure to read and understand this "Use and maintenance manual" in its entirety.

6.2 Switching on the fan



To turn on the fan, follow the instructions in the Manual of the system into which the fan is integrated.



To prevent any electric motor overload, we recommend switching on the radial-flow fans with the damper or the flow regulator closed.

If the valves are controlled automatically, we recommend checking the opening time (in the case of high-pressure, if this setting is too low it may lead to vibrations and "water hammer" effects that are dangerous for the mechanics of the fan).

6.3 Checks after switch-on



Make sure that the direction of rotation of the impeller matches the direction indicated by the arrow (nameplate affixed to the outside of the fan)



Make sure that the fan presents no vibrations.

Check the vibrations in compliance with standards ISO 14694:2003, ISO 10816 and ISO 10816-3.

Recommended vibration limits (mm/s)

RMS: good/acceptable $\leq 7,1$; alarm¹ $> 7,1 \div 11,2$; stop² $> 11,2$.

Recommended measuring points: at the fan mountings, perpendicular to the axis of rotation on the horizontal or vertical plane (near the bearings).

We recommend installing vibration sensors.

Make sure the temperature of the bearings when the fan is running at full capacity is normal
At an ambient temperature of 20 °C, the optimal temperature of the substrates must be less than about 90 °C.

Attention, during the first hours of operation the temperature may exceed the indicated value; it will then stabilise to a lower value.

Temperature limits (°C):

good/acceptable $\leq 90^{\circ}\text{C}$; alarm $> 100^{\circ}\text{C}$; stop $> 120^{\circ}\text{C}$.

Measuring point: outer ring of the bearing regardless of the ambient temperature.

We recommend installing temperature sensors.

Make sure the temperature of the bearings when the fan is running at full capacity is normal.

Make sure the bolts are properly tightened after a few hours of operation.

Check the tension of the belts (where applicable)

Use an ammeter to check the absorption on three line conductors (L1, L2, L3).

6.4 Switching off the fan



- 1) Turn off the fan following the instructions in the Manual of the system into which the fan is integrated
- 2) Set the main switch to "0 (OFF)".



ALWAYS WAIT FOR THE ELECTRIC MOTOR TO COOL DOWN BEFORE STARTING THE FAN AGAIN.

¹ ALARM: warning signal when the vibration level reaches a certain value or when there is a significant change in the vibration level that requires a corrective action. The fan operation may proceed until the cause of the alarm is identified and the corrective action is taken.

² STOP: it indicates the vibration limit beyond which the machine might get damaged. The machine stops as soon as this value is exceeded.

6.5 Emergency stop



In case of an emergency, the fan can be stopped:
by setting the main switch on the electric panel to "OFF";
or by pressing the EMERGENCY STOP button installed on the
Machine into which the fan is integrated.

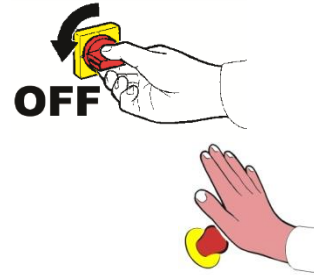

WARNING

DANGER OF CRUSHING/SHEARING:

Do NOT approach the rotor area.

Wait for the impeller to stop.

Before accessing the area, place all necessary maintenance signs and take all the required measures described in Chap. 2

7. MAINTENANCE, CLEANING AND LUBRICATION

7.1 Foreword



All maintenance, cleaning and lubrication operations must be carried out with the Fan in a zero energy state, using all necessary PPE.

Therefore, the staff responsible for maintenance of the Fan must have fully read Chapter 2 "Safety Provisions", in particular:

- the FUNCTION OF THE MAIN SWITCH AND OF THE EMERGENCY BUTTONS: keep in mind that it must be set to "**OFF**" or pressed in case of emergency;
- the FUNCTION OF THE CONTROLS;
- the SYSTEM IN A ZERO ENERGY STATE;
- the OPERATOR;
- the MECHANICAL MAINTENANCE TECHNICIAN;
- the ELECTRICAL MAINTENANCE TECHNICIAN OR QUALIFIED PERSON;
- the DEPARTMENT MANAGER OR SAFETY MANAGER;
- the WARNING LABELS INDICATING THE PRESENCE OF RESIDUAL RISKS, RESTRICTIONS AND OBLIGATIONS;
- the PERSONAL PROTECTIVE EQUIPMENT.

In particular, how to bring the Fan to a ZERO ENERGY STATE, essential for carrying out all the operations safely, and the required Personal Protective Equipment (PPE).

The maintenance operations described here reflect the way in which the **HDF** technician behaves, phase by phase.

They are therefore the procedures to which the technician adheres if future tuning or maintenance has to be carried out.

ANY MAINTENANCE, REPAIR OR REPLACEMENT OPERATION DESCRIBED IN THIS MANUAL MUST BE CARRIED OUT ONLY BY THE CLIENT'S MAINTENANCE TECHNICIAN OR BY THE **HDF** TECHNICIAN.



WARNING GENERAL DANGERS

Each of these operations must be carried out by a SINGLE professionally qualified technician (unless otherwise indicated),

AND NOT BY SEVERAL PEOPLE.

Check for the absence of any type of energy on the Fan.

Remember to put a lock on the switch.



The mentioned key must be:

- kept by the Maintenance Technician;
- or handed over to the Safety Manager.



IT MUST NEVER BE LEFT IN THE PADLOCK.

Fence off the area and place a sign that indicates works in progress on the mains switch and on the fence:

"MAINTENANCE IN PROGRESS".





NOTE:

IF THE DEVICE IS KEPT CONSTANTLY ADJUSTED, AS DESCRIBED IN THIS MANUAL, THERE IS NO NEED FOR OTHER MAINTENANCE, OTHER THAN THOSE INDICATED HERE.



CAUTION

Following intervention that involved dismantling and re-assembly of important parts, always check the continuity of the earthing circuit.

It is forbidden to carry out maintenance operations on moving units.
At the end of the maintenance operations, you must re-assemble the fixed guards.

General information:

Only use equipment suitable for maintenance operations.
Comply with the frequency and intervention methods outlined in this Manual.

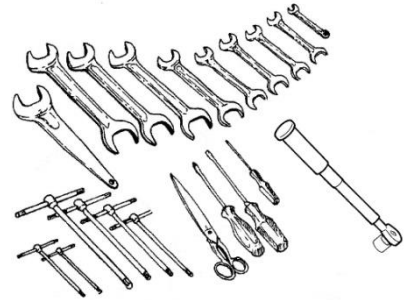

WARNING

To correctly carry out cleaning, use a bag for equipment and detergents authorised in the Country where the Fan is installed and use them as needed. Only use equipment suitable for cleaning operations.

NEVER use equipment with sharp edges that could damage the mechanical elements.

If the work must be done at height, use an adequate safety ladder.

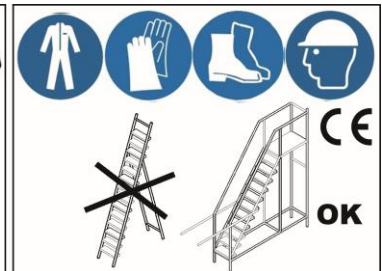
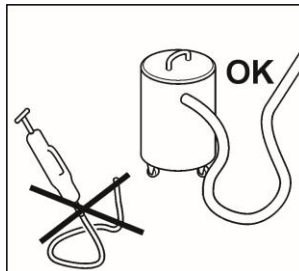
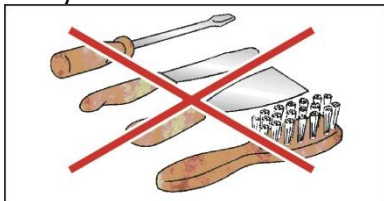

It is forbidden the use of solvents such as petrol, trichloroethylene, diluents since they would damage the Machinery or parts thereof

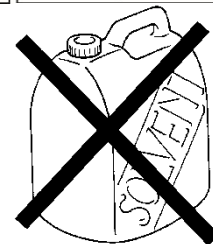

If necessary, cover the Motors with cellophane or appropriate material.



Check that the amount and/or type of lubricants used match the indications. **Never mix lubricants of different quality or brand.**

Long periods of storage will reduce the efficiency of the oil or grease even if stored properly; therefore, they must be replaced every two years.

During long storage period, lubricated rotating parts should be rotated every month, even by hand where possible, to restore the lubrication (for ex. Rotate the bearings by hand to re-establish the protection of rotating elements)

Do NOT use wire sponges or cleaning products that may pollute or alter the characteristics of the lubricants.

The product must be cleaned with adequate means and detergents that do not affect the painting or the gaskets; it is strictly forbidden to clean or wash the product with water jets.

HDF disclaims any liability in case of failure to comply with the maintenance intervals reported in this manual and in the documentation attached to it, or if the maintenance works are assigned to incompetent staff or that adopts procedures or uses lubricants with other characteristics than those indicated herein.



When ordering spare parts, please order only original spare parts.

If necessary, contact **HDF S.r.l.**

If properly carried out, maintenance works can reduce the downtimes after a failure to a minimum. Repairs carried out in due time will prevent any further deterioration.



Based on the hours of operation, the maintenance works can be classified under:

scheduled maintenance:

maintenance works carried out at pre-set intervals (example lubrication or replacement of worn parts);

occasional maintenance:

works carried out in the event of an accidental malfunction and/or fault (example replacement of a fuse or a light bulb).

Based on the technical/economic importance or the frequency of intervention, the following types can be distinguished:

routine maintenance:

works involving simple execution and low technical/economic value;

non-routine maintenance:

repair and/or replacement intervals of significant technical and/or economic importance; normally, they are necessary following rare or unexpected faults and require the use of qualified **HDF S.r.l.** or Client staff.

Such as preventive inspections that guarantee safe use of the Fan.

7.2 Scheduled maintenance

To guarantee the complete efficiency of the fan, you need to comply with the times and methods indicated below.

The checks related to maintenance operations are:

- general visual inspections;
- functional tests;
- checking the efficiency of the safety devices;
- checking the guards are intact, efficient and fastened;
- checking the noise generated by the bearings;
- restoration of any calibration;
- replacement of pneumatic components;
- replacement of mechanical components in general;
- checking the proper tensioning of the drive belts;
- checking the correct balancing of the impeller.

See table "MAINTENANCE INTERVALS"

MAINTENANCE INTERVALS

Intervention	See Par.	300 hours	1000 hours	1500 hours	2500 hours	4500 hours	9000 hours	20000 hours	Notes
Screw cleaning	7.2.1					X	X		A (*)
Impeller Cleaning (for clean fluids)	7.2.2						X		A
Impeller Cleaning (for dusty fluids) (**)	7.2.3	Cleaning intervals cap. 7.2.3							A (*)
Impeller condition Check (for clean fluids)	7.2.4						X		
Impeller condition Check (for dusty fluids)	7.2.4			X					
Damper cleaning (for clean fluids)	7.2.5						X		A
Damper cleaning (for dusty fluids) (**)	7.2.5	Cleaning intervals cap. 7.2.5							A (*)
Bearings and housings	7.2.6			X					A
Fastening of all fixed parts	7.2.7			X					A
Toothed belts	7.2.8			X					A
V-belts	7.2.9				X				A
Fan vibration check	7.2.10		X						B
Impeller disassembly	7.2.12							X	A
Motor Revision	7.2.13							X	A(***))
Coupling replacement	7.2.14						X		
Check of all the electrical system components	7.2.15					X			A
Check of the legibility of the warning labels for residual risks, restrictions and obligations	7.2.16		X						
Coupling lubrication with grease	7.2.14	Lubrication intervals chap 7.2.14.1 and 7.2.14.2 Read also chap. 7.2.6.4							A (*)
Bearing lubrication with grease	7.2.6	Lubrication intervals chap 7.2.6.1 Read also chap. 7.2.6.4							B (*)
Pillow block lubrication with grease	7.2.6	Lubrication intervals chap 7.2.6.2 Read also chap. 7.2.6.4							B (*)
Separated bearings and pillow block lubrication with oil	7.2.6	Lubrication intervals chap 7.2.6.3							A (*)

NOTES:

For the points marked with:

(*) the tripping time value is only indicative.

(**) to consider dusty fluid if dust content is $\geq 100 \text{ mg/Nm}^3$.

(***) intervention and related intervals shall be in accordance with Motor manufacturer manual

The value refers to a clean and dust-free place.

A indication of verification/operations to perform at zero energy state.

B indication of the checks to be performed with the machine running.

C indication of the checks to be performed immediately after stopping the machine.

NOTE: in all cases, after a long period of inactivity of the fan (over 6 months), it is necessary to check the lubrication of all the lubricated components (oil and/or grease) and replace the oil (for oil lubricated ones) and grease with new grease (for the grease lubricated ones)

7.2.1 Fan casing cleaning

Do not use compressed air, but a vacuum cleaner, to remove all dust or any other residues.

If there are small lumps, use a cloth (or sponge) slightly dampened with water.

NEVER use high-pressure washers



7.2.2 Impeller Cleaning (for clean fluids)

WEAR PROTECTIVE GLOVES

Rotate the blades manually.



Do not use compressed air, but a vacuum cleaner, to remove all dust or any other residues.

If there are small lumps, use a cloth (or sponge) slightly dampened with water.



7.2.3 Impeller Cleaning (for dusty fluids)



WEAR PROTECTIVE GLOVES

Rotate the blades manually.

Do not use compressed air, but a vacuum cleaner, to remove all dust or any other residues.

If there are small lumps, use a cloth (or sponge) slightly dampened with water.

You must ensure that the dust deposits cannot lead to excessive impeller imbalances: the user must install an adequate vibration monitoring system in compliance with standard ISO 14694.

In case of abrasive dust, the vibrations may depend on the wear state.

In this case, the impeller must be replaced as soon as possible.

In case of welded impellers, check the condition of the welds: they should present no cracks.



Attention: it is not possible to define a standard maintenance interval for fans working in a dusty / abrasive environment. Define the interval of cleaning, checking and maintenance according to the conditions of use of the machine. After a certain period of monitoring, define the most suitable interval for the use of the machine. Continuously check the vibrations of the machine and promptly intervene if the levels exceed the indicated threshold values.

7.2.4 Impeller condition Check

Visually check that the impeller is free from defects due to wear and corrosion.

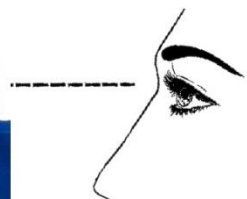

7.2.5 Dampers' cleaning



WARNING
CUTTING HAZARD
WEAR PROTECTIVE GLOVES



Do not use compressed air, but a vacuum cleaner, to remove all dust or any other residues. If there are small lumps, use a cloth (or sponge) slightly dampened with water.

Once you have completed the cleaning, DRY PROPERLY with the moistened cloth. Proceed to dampers' cleaning based on the dust accumulated.

For machines servicing rooms classified as "clean" (dampers with servocontrol), provide for a periodic inspection.



Attention: it is not possible to define a standard maintenance interval for fans working in a dusty / abrasive environment. Define the interval of cleaning, checking and maintenance according to the conditions of use of the machine. After a certain period of monitoring, define the most suitable interval for the use of the machine. Frequently check the condition of the dampers and its operating mechanisms to avoid any damage to the machine.

7.2.6 Bearings and housings

Bearings' condition

Check for any anomalous noise, vibrations or overheating of the bearings frequently.

Visually and acoustically check that the bearings do not create noise or excess vibrations and do not present clearances or incorrect movements.

Contact **HDF S.r.l.** in case of need for assistance or for spare parts.



Cleaning the bearings

Upon disassembly of ball or roller bearings, remove the bearing housings from the shafts.

Put the bearing housings in a special container with oil or kerosene and let them soak for about 1 hour: move them with your hand to help to remove the particles of dirt.

Remove any old traces of oil and grease from the housing and clean it with white kerosene or another suitable solvent.

Dry all the parts with a clean cloth to prevent the dilution of the new lubricant in contact with the solvent.

If the bearing grease is heavily oxidised, soak it in light oil (SAE10) at 90÷110°C and then proceed with the cleaning.

Rotate the bearing in the clean oil to remove any traces of solvent.

Remove from the oil bath and add lubricant.

7.2.6.1 Antifriction bearing lubrication with grease (**SEPARATED BEARINGS**)

The bearings of the fans shipped already assembled have been lubricated at the HDF, premises but their lubrication condition should be checked prior to start-up.

The bearings of the fans shipped unassembled or those shipped as replacement or spare parts are not usually greased.

Before greasing the bearing, clean it thoroughly.

Remove any trace of rust preventative or dirt using clean oil.

Then dry the bearing carefully with air or clean rags.

Remove any trace of rust from the shaft, the bearings and their housings before proceeding (use wire wool without removing material from the shaft as this would damage its shape and finishing).

For best results, we recommend using the same grease throughout the entire lifespan of the part because not all greases are chemically compatible.

If you have to use a different lubricant, remove any trace of the old lubricant before applying the new one.

Use a pneumatic grease gun.

Fill the bearing housing up to about 1/3.

Any excess grease may cause bearing overheating.

For separate grease-lubricated supports where there are no labyrinth seals or an appropriate exhaust valve, after **10-12** lubrication operations, remove the cover and completely replace the grease, cleaning both the support and the bearing well. After cleaning, re-grease the system paying attention to fill well the area between the outer ring and the outside of the bearing, the adjacent area, using the first filling quantity indicated in the following table.



Initial fill and Re-lubrication

Bearings can be filled with the following types of grease:

- SKF: LGMT 2
- SKF: LGHP 2

For standard machines the LGMT 2 (relatively low rotation speed and standard temperatures) is installed, while LGHP 2 is installed for fast machines and / or working with high temperature fluid.

LGMT 2 grease is a grease composed of mineral oil and lithium soap (thickener), NLGI 2 consistency class, with dripping point > 180 ° C (DIN ISO 2176), penetration 265/295 mm / 10 (DIN ISO 2137), maximum temperature 120 ° C.

LGHP 2 grease is a grease composed of mineral oil and Di-urea (thickener), consistency class NLGI 2-3, with dripping point > 240 ° C (DIN ISO 2176), penetration 245/275 mm / 10 (DIN ISO 2137), maximum temperature 150 ° C.

Depending on the type of bearing, the quantity of grease relative to the initial filling is shown below.

For smooth long lasting operation, we recommend checking the lubrication of the bearings frequently.

For antifriction bearings is usually intended a maximum temperature of 75/85 ° C (measured at the outer ring) when used in a regular workshop environment, even though higher temperatures are acceptable (see Chapter 6.3).

The lubrication intervals shown in the table below refer to the aforementioned conditions and are indicated according to the different types of bearings and their rotational speed N.

Shaft diameter [mm]	Support	Grease quantity [gr]	Bearing	Relubrication intervals [hour] vs rpm									
				750	1000	1250	1500	1750	2000	2250	2500	2750	3000
30	507	50	22207 EK	3380	2510	1990	1650	1400	1220	1060	930	830	740
			2207 EK	33800	25100	19900	16500	14000	12200	10600	9300	8300	7400
35	508	60	22208 EK	3010	2230	1760	1450	1240	1080	920	810	710	640
			2208 EK	30100	22300	17600	14500	12400	10800	9200	8100	7100	6400
40	509	65	22209 EK	2640	1940	1530	1260	1070	930	790	690	600	540
			2209 EK	26400	19400	15300	12600	10700	9300	7900	6900	6000	5400
45	510	75	22210 EK	2510	1840	1440	1170	990	850	730	630	550	490
			2210 EK	25100	18400	14400	11700	9900	8500	7300	6300	5500	4900
50	511	100	22211 EK	2380	1750	1340	1090	910	780	660	580	510	450
			2211 EK	23800	17500	13400	10900	9100	7800	6600	5800	5100	4500
55	512	150	22212 EK	2250	1650	1250	1000	830	700	600	520	460	410
			2212 EK	22500	16500	12500	10000	8300	7000	6000	5200	4600	4100
60	513	180	22213 EK	2120	1550	1160	910	740	620	530	470	410	-
			2213 EK	21200	15500	11600	9100	7400	6200	5300	4700	4100	3700
65	515	230	22215 EK	2020	1480	1090	860	690	580	490	420	-	-
			2213 EK	20200	14800	10900	8600	6900	5800	4900	4200	3700	3200
70	516	280	22216 EK	1920	1400	1030	800	650	540	450	-	-	-
			2216 EK	19200	14000	10300	8000	6500	5400	4500	3800	3200	2800
75	517	330	22217 EK	1810	1320	960	740	600	490	400	-	-	-
			2217 K	18100	13200	9600	7400	6000	4900	4000	3300	2800	2400
80	518	430	22218 EK	1710	1250	900	690	550	450	-	-	-	-
			2218 K	17100	12500	9000	6900	5500	4500	3600	2900	2400	2000
90	520	630	22220 EK	1700	1130	790	590	460	-	-	-	-	-
			2220 K	17000	11300	7900	5900	4600	3700	2700	2100	1700	1300
100	522	850	22222 EK	1680	1020	690	500	-	-	-	-	-	-
			2222 K	16800	10200	6900	5000	3700	2900	1900	1300	900	700
110	524	1000	22224 EK	1410	890	610	430	-	-	-	-	-	-
125	528	1400	22228 EK	1110	720	490	-	-	-	-	-	-	-
140	532	2000	22232 EK	990	620	-	-	-	-	-	-	-	-

The color of the cells indicates the type of first filling grease depending on the size of the bearing and the speed:

- SKF – LGMT2
- SKF – LGHP2

For temperatures at the outer ring of the bearing between 90 °C and 110 °C, the lubrication interval must be halved for each $\Delta T = 15^\circ \text{C}$. Also, if used in dusty, humid, hot or corrosive environments, the interval indicated in the table must be reduced accordingly.

If used under normal conditions, i.e. without being affected by external heat sources, the amount of oil to be added can be determined using the formula:

$$GP = 0.005 \cdot D \cdot B$$

where:

- GP = amount of grease to be added in grammes
- D = bearing outer diameter in mm.
- B = total bearing width in mm.

7.2.6.2 BEARING HOUSING (MONOBLOCK) lubrication with grease

Initial fill and Re-lubrication

Bearing Housing bearings are pre-lubricated (initial fill performed by **HDF S.r.l.**) with a lithium-based grease with EP additives, consistency number NLGI 2, base mineral oil viscosity $\nu = 150 \text{ mm}^2/\text{s}$, temperature range from $-20 \text{ }^\circ\text{C}$ to $+120 \text{ }^\circ\text{C}$, dropping point $>180 \text{ }^\circ\text{C}$.

The grease stays inside the bearing thanks to the cover installed on one side and to the special screen installed on the other side but it still requires re-lubrication at regular intervals with the adequate amounts of grease. With this type of bearings, there is no danger of over-lubrication because all the excess grease is pushed towards the centre of the casing where there is a discharge hole that also acts as an anti-condensation vent.

For smooth long lasting operation, we recommend checking the lubrication of the bearings frequently.

For antifriction bearings is usually intended a maximum temperature of $75/85 \text{ }^\circ\text{C}$ (measured at the outer ring) when used in a regular workshop environment, even though higher temperatures are acceptable (see chapter 6.3).

The lubrication intervals shown in the table below refer to the aforementioned conditions and are indicated according to the different types of bearings and their rotational speed N.

The table below shows the re-lubrication intervals and the amount of grease necessary for each bearing.

Pillow block model	Relubrication quantity [gr]	Relubrication intervals [hour] vs rpm									
		750	1000	1250	1500	1750	2000	2250	2500	2750	3000
20	10	41710	30560	24020	19720	16710	14470	12750	11390	10280	9360
30	15	29350	21840	17360	14400	12290	10710	9490	8520	7720	7060
40	20	27230	19550	15110	12250	10250	8790	7670	6800	6090	5510
50	30	26020	18340	13990	11210	9290	7900	6850	6020	5360	4820
60	40	22860	15900	12000	9530	7840	6630	5710	5000	4200	3580
70	50	19790	13470	9990	7830	6370	5330	4280	3510	2940	2500
80	60	18280	12250	8980	6970	5620	4670	3620	2880	2340	1940
90	80	16990	10900	7720	5830	4600	3370	2560	2000	1480	1120
100	100	14170	9080	6430	4850	3830	2690	1980	1500	990	670

7.2.6.3 Antifriction bearing lubrication with oil

HDF S.r.l. recommends oil lubrication for high-speed or high-temperature applications that exclude the use of grease.

To avoid losses during transport and installation, bearing house and pillow blocks lubricated with oil **are NOT pre-lubricated**. It is necessary to fill with oil before running the fan.

If the indicator is "by eye", the level represents the centerline of the indicator, whereas if is "pipette" the level must be between the minimum and maximum mark. All levels are to be considered in a static condition, i.e. with the fan off. It is necessary to wait for the right time for the oil level stabilization.

The oil lubrication methods used for both pillow block bearings and separated bearings are oil baths or ring oilers.

The oil should be changed once every 6 months. If used in particularly adverse conditions (very dusty environments or that lead to premature oil oxidation) we recommend shortening the period.

We recommend the use of MOLIGUARD GEAR SINT EP 68, a synthetic additive EP with viscosity ISO VG 68 and flash point > 200 ° C.

In the case of bearings mounted on separated bearings in oil bath, in addition to check the level of the indicator, it is also necessary to check the level with respect to the support plane of the support.

Below is indicated the level reported in the filling schedule for separated bearings with oil-bath lubrication.

Shaft Diameter [mm]	Support	oil level [mm]
40	509	24.0
45	510	29.0
50	511	28.5
55	512	32.0
60	513	27.0
65	515	38.0
70	516	34.5
75	517	35.5
80	518	47.0
90	520	45.0
100	522	53.5
110	524	57.0
125	528	51.5
140	532	53.2



All levels refer to static conditions.

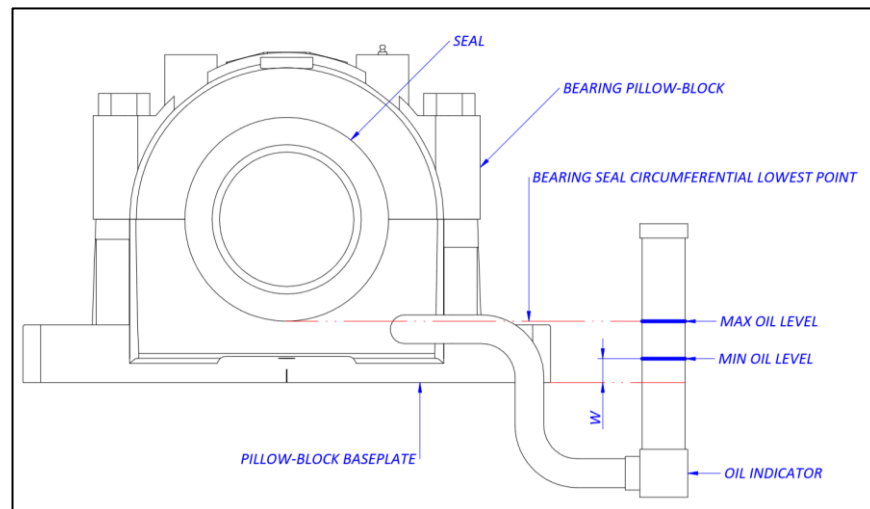

Oil level indicator

7.2.6.4 Lubrificant types and maintenance notes

GREASE

Depending on the type of bearing house and pillow blocks, it is necessary to carefully follow the indications below regarding the type of lubricant and the re-lubrication and replacement operations. Before using other types of lubricant than those indicated, it is necessary to check their **TOTAL** compatibility. It is advisable to use the same grease / oil indicated by HDF in the manual or in the dedicated drawing.

In drawing, can be indicated a lubricant different from the standard one (better performing); in this case follow the indicated lubricant. It is necessary to check the general compatibility with the following tables of the grease additives / the oil additives used for re-lubrication.

Below are the tables with the basic compatibility:

Thickener compatibility chart

	Lithium	Calcium	Sodium	Lithium complex	Calcium complex	Sodium complex	Barium complex	Aluminium complex	Clay (Bentonite)	Common polyurea ¹⁾	Calcium sulphonate complex
Lithium	+	●	-	+	-	●	●	-	●	●	+
Calcium	●	+	●	+	-	●	●	-	●	●	+
Sodium	-	●	+	●	●	+	+	-	●	●	-
Lithium complex	+	+	●	+	+	●	●	+	-	-	+
Calcium complex	-	-	●	+	+	●	-	●	●	+	+
Sodium complex	●	●	+	●	●	+	+	-	-	●	●
Barium complex	●	●	+	●	-	+	+	+	●	●	●
Aluminium complex	-	-	-	+	●	-	+	+	-	●	-
Clay (Bentonite)	●	●	●	-	●	-	●	-	+	●	-
Common polyurea ¹⁾	●	●	●	-	+	●	●	●	●	+	+
Calcium sulphonate complex	+	+	-	+	+	●	●	-	-	+	+

Base oil compatibility chart

	Mineral/PAO	Ester	Polyglycol	Silicone: Methyl	Silicone: Phenyl	Polyphenylether	PFPE
Mineral/PAO	+	+	-	-	+	●	-
Ester	+	+	+	-	+	●	-
Polyglycol	-	+	+	-	-	-	-
Silicone: Methyl	-	-	-	+	+	-	-
Silicone: Phenyl	+	+	-	+	+	+	-
Polyphenyl-ether	●	●	-	-	+	+	-
PFPE	-	-	-	-	-	-	+

+ = Compatible
 ● = Test required
 - = Incompatible

¹⁾ SKF high performance, high temperature bearing grease LGHP 2 is not a common polyurea type grease. It is a di-urea bearing grease, which has successfully been tested for compatibility with lithium and lithium complex thickened greases i.e. LGHP 2 is compatible with such greases.

The following table shows the compatibility of the greases indicated by **HDF S.r.l.**

	SKF – LGMT 2	SKF – LGHP2	ROL OIL – LITEX EP 2
SKF – LGMT 2	+	+	-
SKF – LGHP2	+	+	-
ROL OIL – LITEX EP 2	-	-	+

+ = compatible
 - = NOT compatible



Warning: the compatibility does not indicate that the performance remains the same. To maintain the performance, operating temperature and bearing life, it is necessary to use exactly the indicated products. Compatibility is only an indication of the chemical / physical affinity of lubricants, ie they will continue to perform the lubricating function, not chemically untying, totally losing the lubricating properties, but with different performances.

If it is necessary to use an incompatible grease it is necessary to completely remove the lubricant from both bearing house / pillow blocks and the bearing itself by using solvents (diluent, kerosene, etc ...), compressed air and rag.

Reapply the new lubricant as if it were the first filling ie respecting the quantity and paying attention to completely penetrate the grease inside the bearing (by perfectly wrapping the balls / rollers and filling all the space between the rings) and adding the remaining externally along the tree.

Run the fan for a few hours, keeping the temperature and vibration monitored, and repeat the cleaning and filling procedure again.



Warning: Absolutely forbidden to use greases containing Graphite, Molybdenum Disulphide and other elements / additives not suitable for use with rolling bearings.

OIL

Different is when we are in the presence of oil lubrication. **NEVER** mix different oils regardless of compatibility. If necessary replace the oil with another, completely empty the oil inside the bearing house / pillow blocks and replace with the new one.

When replacing, pay attention to the oil replaced. If there are anomalies or particles, it may indicate excessive bearing wear or contamination. In these cases, before the system is restarted, evaluate the cause and intervene.

7.2.7 Fastening of all fixed parts

Check the tightening torque of the Fan screws.

		Cl. 8.8	
Screw	Step	Preloading	Tightening Torque
M	[mm]	N	Nm
8	1.25	16815	27
10	1.5	26774	52
12	1.75	39039	89
16	2	73790	217
20	2.5	115297	417
24	3	166028	714
30	3.5	265722	1408
36	4	388751	2446

Note: The tightening torque generates a preload equal to 80% of the yield of the screw. (The considered friction coefficient is equal to 0.13 – new unlubricated bolt). It is necessary to reduce the tightening torque by 25% when is used MOS2 (or similar).

To fix the bearing housing to the carpentry follow the values the screws tightening torque shown in the following table:

		Cl. 8.8	
Screw	Step	Preloading	Tightening Torque
M	[mm]	N	Nm
10	1.5	25742	50
12	1.75	26273	60
16	2	34044	100
20	2.5	35910	130

For all commercial elements (e.g. bearing supports, electric motors, etc.) refer to what is indicated by the manufacturer.

The following table shows the correspondence between the fan holes and the screws.

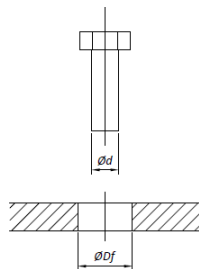

ϕd	ϕdf			
	CARPENTRY AND FLANGE	INLET CONE	BASEMENT	BOLTS/NUTS WELDED
8	12	16	16	9
10	14	18	18	11
12	16	20	20	13
16	20	24	24	17
20	26	30	30	21
24	30	34	34	25
30	36	40	40	31

Notes:

- use only cl. 8.8 screws for all the couplings;
- the minimum length of the screw is equal to tightening thickness + overall dimensions of the lockwasher and nut + $d/2$;

7.2.8 Toothed belts

Fan control motor belt tensioning and pulley alignment check

Check the correct tightening of the belts:

- after the first operating period (about 5 days);
- - then, every 3-4 months;

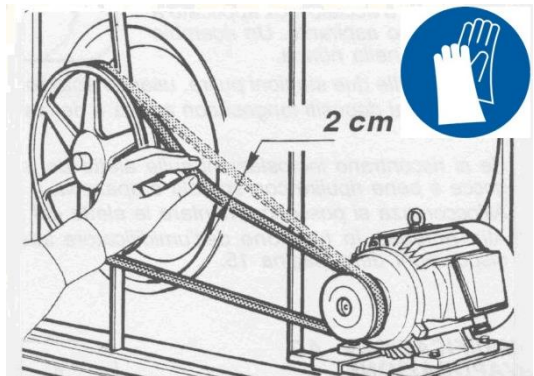

if necessary, tighten correctly using the adjustment system (2) (arrow of about 2 cm, working on the intermediate point of the belt between the pulleys).

Pay utmost attention not to overtighten the belt.

Excess tightening may damage the bearings.

Check the correct alignment of the pulleys every 2500 hours.

Use a template to check the correct alignment and if necessary, adjust the pulley to obtain it;

Make sure that:

- the belts are positioned correctly in their compartments
- the toothed compartments are not worn.

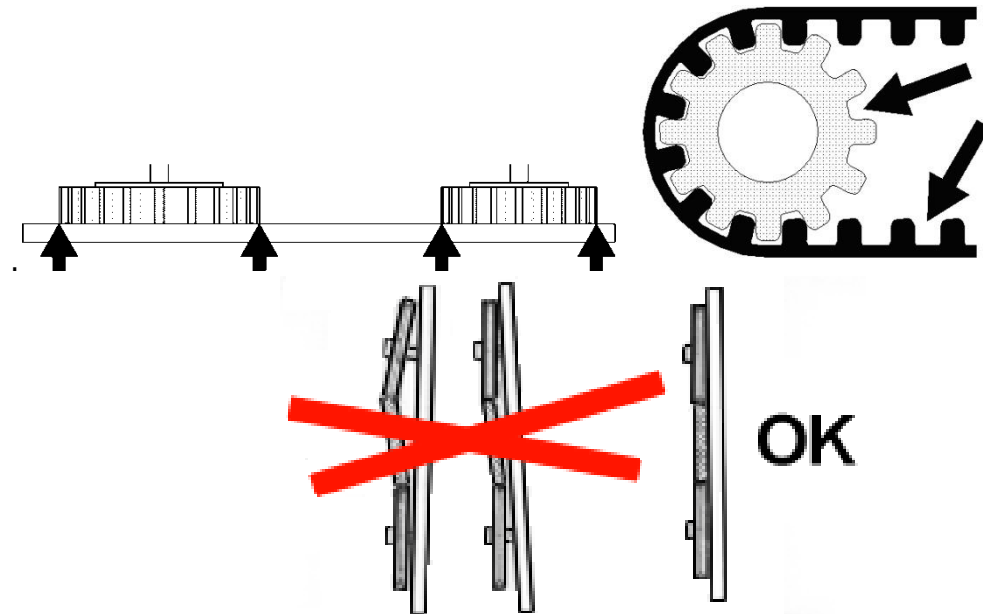

Toothed belt cleaning

To clean the toothed belts

NEVER use chemical agents: they may damage them.

Use a vacuum cleaner and then a dry cloth.



7.2.9 V-belts

To mount a V-belt drive system:

- clean the fan and motor shafts. Make sure they present no signs of corrosion;
- clean the pulley hubs and cover them in lubricating oil to facilitate shaft insertion;
- remove any traces of oil, grease, rust or burrs from the pulleys;
- install the fan pulley on the fan shaft and the motor pulley on the motor shaft.
- Do not use a hammer to fit the pulleys in because you may damage the bearings.
- Fix the pulleys.

Alignment check

Make sure that each pulley is as close as possible to its mounting; the pulley and the belts should not touch the mounting.

- Move the motor so that you can remove the belts effortlessly.
- Do not force the belts and do not insert tools in the grooves of the pulleys

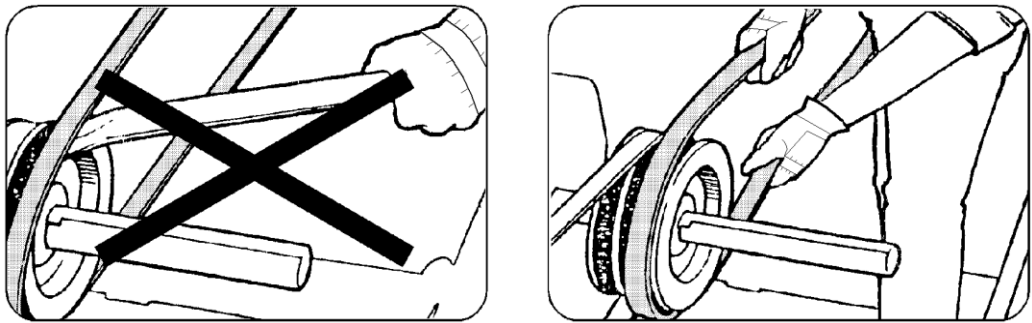

- use a rigid ruler or a tightrope to adjust the motor and fan shafts so that they are parallel. The belts should be at a straight angle with the shafts.

Incorrect alignment may lead to excessive belt wear.

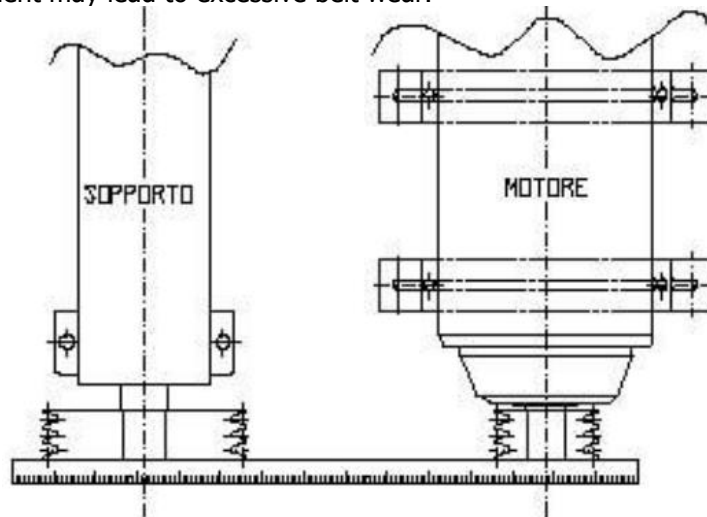

checking the correct belt tension

The correct tension of the belts is essential for the proper operation of the V-belt drive system.

- Before installing the belts, ensure that the direction of rotation of the motor is correct.
- Tighten the belts by sliding the motor on its base: the tension of the belt must be correct in order for the system to be as efficient as possible. Excessive belt tension may over-stress the bearings.

Check the alignment again.

Use a dynamometer and a torque wrench.



To check the belt tension, you must:

Esempio: T=1500 mm

f=1500:100 x 1.5 = 22,5 mm

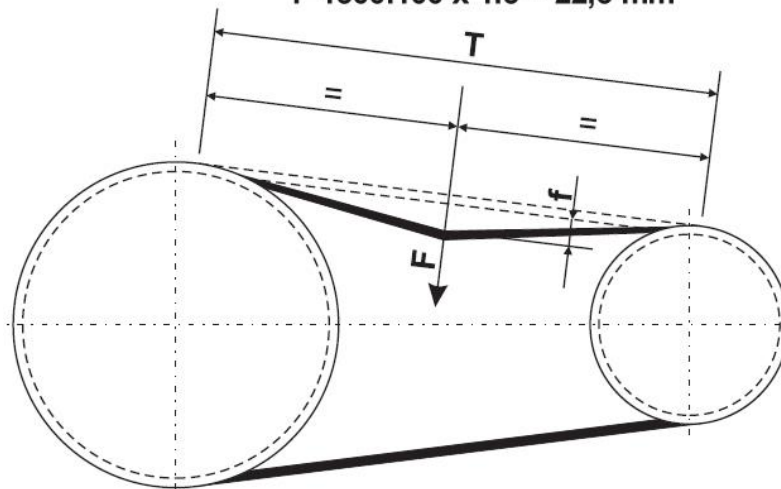

- 1) Measure section "T";
- 2) For each belt apply, using the torque wrench, at half "T" a perpendicular force "F" capable of causing an arrow "f" of 1.5 mm for every 100 mm of "T";
- 3) Compare the value "F" provided by the torque wrench with the values "F1" and "F2" in the Table.

BELT SECTION	EXTERNAL DIAMETER SMALL PULLEY	RPM SMALL PULLEY	F ¹ MIN. NEWTON	F ² MAX. NEWTON
SPZ	50 + 90	1200 + 5000	10	15
	100 + 150	900 + 1800	20	30
	155 + 180	600 + 1200	25	35
SPA	90 + 145	900 + 1800	25	35
	150 + 195	600 + 1200	30	45
	200 + 250	400 + 900	35	50
SPB	170 + 235	900 + 1800	35	45
	250 + 320	600 + 1500	40	60
	330 + 400	400 + 900	45	65
SPC	250 + 320	900 + 1800	70	100
	330 + 400	600 + 1200	80	115
	440 + 520	400 + 900	90	130

Check the correct positioning of the belts in their seat.

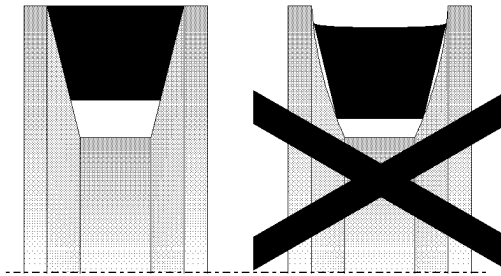

Make sure the belts are in perfect condition and do not present signs of wear or frayed sections.

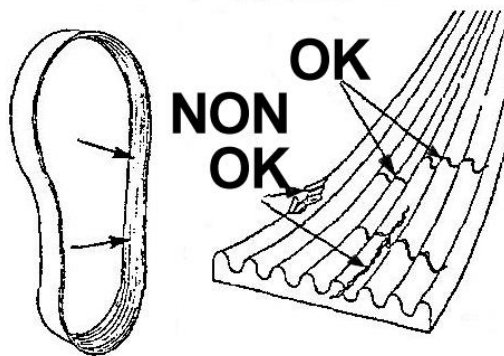

If necessary, replace them.

After carrying out all the necessary checks and tightening the belt correctly, tighten the four screws with the nuts.

Reinstall the fixed guard of the belts and secure it with the relevant screws.

7.2.10 Fan vibration check

The vibration check is extremely important in the case of Fans.

The service life of some of the components depends on the vibration condition.

The main causes of vibration can be:

- a) imbalances of the rotating masses;
- b) structural resonance;
- c) thermal growths;
- d) rigid connections between fans and ducts.
- e) damaged and cracked welds on the support frames
- f) incorrectly tightened locking nuts or that do not have a washer underneath.

For machines with antifriction bearings, where the most important aspect is to check the condition of the bearings, we recommend using special monitoring equipment, able to define the acceleration spectrum over a field of frequencies that allows you to readily identify any abnormal values that may indicate a bearing fault



a) imbalances of the rotating masses;

- a1) Dust accumulation or deposits on the impeller,
- a2) Impeller corrosion or erosion,
- a3) Shaft and impeller deformation due to temperature

Any accumulation of the conveyed materials may result in excessive vibrations, leading to malfunctions.

For impeller cleaning, see par. 7.2.2 / 7.2.3.

b) Structural resonance

Such phenomenon must be removed by changing (usually increasing) the stiffness of the resonant structure or component so that the fan works below the lowest resonant frequency.

c) Thermal growths

They may occur on fans that operate with hot gases.

The temperature gradients should be kept as low as possible over time, within the limits allowed by the process, because they are directly proportional to the stress applied to the materials.

Therefore, you should avoid as far as possible any thermal shocks because they may cause cracks and breakages in the impeller and deformation in the shafts.

Particularly long shafts exposed to hot gases at a standstill for long periods of time may suffer permanent deformations.

d) Rigid connections between fans and ducts

The fan should not withstand the weight of any external load. Flexible connections must be provided between ducts and fan inlet/outlet.

7.2.11 Impeller assembly

Bring the impeller in an accessible position.

1. Remove any inlet connection channels
2. Remove the screws fixing the inlet cone to the fan casing
3. Gently remove the inlet cone paying attention not to damage the gasket.
4. Measure the distance between the impeller and the rear side of the fan casing; you will need to respect it upon impeller re-assembly. Changing this distance may reduce the functional characteristics of the fan.

For impellers installed directly on the shaft, the head screw is tightened on the shaft of the fan in such a way that the extractor presses against the end of the shaft.

The impeller hub is connected to the extractor by means of n° 02 screws.

7.2.12 Impeller disassembly



**WARNING
DANGER SUSPENDED LOADS**

- In case of corrosion remove rust using special oils or solvents. Do not use hammers and/or levers.
- Remove the head screw (aa) and the extractor (aa).
- Tighten the screw (aa) in the slot on the fan shaft.
- Install the extractor (aa) using the screws (aa)
- Insert the screw (aa) in the extractor hole (aa) and rotate to the right to release the impeller.

**ATTENTION!
THE IMPELLER CAN BE VERY HEAVY!**

To lift the impeller, follow the instructions in Chapter 4 LIFTING AND INSTALLATION INSTRUCTIONS.

- Remove the impeller
- Remove the extractor (3) and the screw (4)

7.2.13 Motor revision

Please refer to motor manufacturer manual for the maintenance intervention and related intervals.

In case of motor replacement
Refer to the wiring diagrams in Chapter 8 of this Manual.

Disconnect the motor from the coupling/impeller.
Remove the coupling/impeller from the fan.

Loosen the screws fixing the cover of the box.
Remove the box cover and, following the wiring diagrams, disconnect the motor from the power supply cables.



Coated and processed parts should be protected with cardboard, wood or rags.

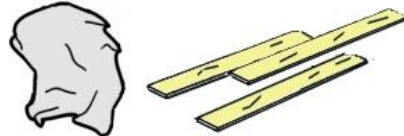

WARNING DANGER SUSPENDED LOADS

Insert the strap hooks in the motor eyebolts.

Make sure that the hook pawl is closed and cannot come out.

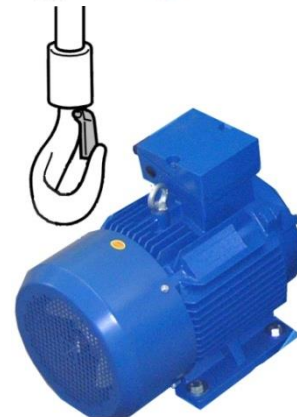

7.2.14 Coupling replacement

On some Fans, you need to install the coupling that connects the electric motor shaft to the impeller bearing.

The couplings used by **HDF S.r.l.** are usually:

- rigid toothed coupling;
- blade coupling;
- rubber coupling;

The coupling consists of a female and a male side.

The female side of the coupling is inserted into the bearing while the male side is fixed to the shaft of the electric motor.

Coupling centring and alignment

The following procedure is purely indicative. For more detailed steps, refer to the coupling manual attached.

Ensure that the alignment of the coupling is correct (parallelism and centring); proceed as follows:

Radial centring

- 1) Measure the value C_r ;
- 2) Shim the feet of the electric motor until it falls within the limits indicated in the Table.

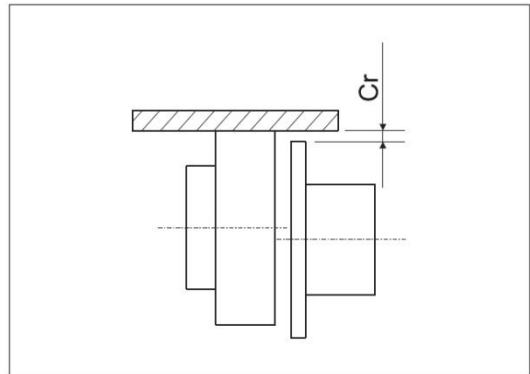

Angular centring

- 1) Measure the values a and b in at least 4 points and determine the maximum variation $b-a$;
- 2) Take adequate measures to bring it within the limits indicated by the manufacturer

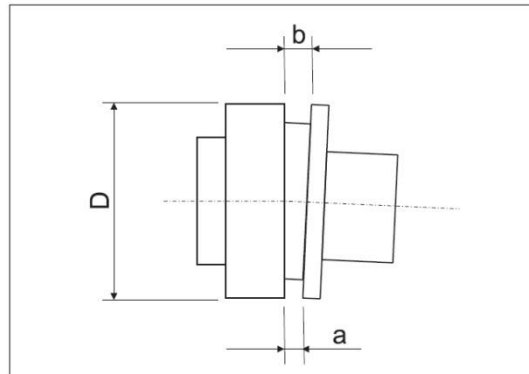

Important:



For installation instructions, assembly tolerances and lubrication specifications, refer to the manual provided by the Manufacturer of the coupling.

7.2.14.1 Lubrication of standard gear coupling "MAINA" – GO-A

If a standard MAINA gear coupling, GO-A series, is installed, below instructions shall be followed:

1. After the hubs shrinkfitting and the positioning of the gear sleeves and side flanges, fill with grease all the spaces between hubs and sleeves using a spatula. After closing the gear coupling, spread a slight mastic film on the flange connection surfaces.
2. Close the coupling and tighten all the screws according to the tightening torques indicated (table below), then complete lubrication using all the grease nipples and / or plugs (N ° 2 for half-coupling).

GO-A Size	SEAL OR. TN414	Tightening Torque (Nm)
0	OR 68	18
1	OR 85	36
2	OR 107	36
3	OR 133	65
4	OR 152	65
5	OR 177	150
6	OR 209	150
7	OR 234	150
8	OR 253	220
9	OR 279	400
10	OR 304	400
11	OR 355	520

3. Lubricate through the grease nipples, verify that the grease is really filling the gear coupling; should the grease enter the coupling with difficulty, open a breather by removing a plug or a grease nipple.
4. At the end of the lubrication, make sure that the couplings are completely filled with grease, then reassemble the plugs and / or greasers, checking their tightening.
5. Gear coupling must be lubricated regularly every 3-4 months.
This initial interval is recommended for integral seals, industrial applications, non-aggressive environments, medium and heavy duty services and ambient temperatures between 0°C and 70°C. After the first year of use and observation and after verifying the results, the time intervals can be extended up to 6 months. A certain amount of grease must be created in the coupling during lubrication. To let all the old grease out, remove a plug or a grease nipple at 180° from the new grease filling point and pump the new grease until this comes out from the breather. At the end of the operation, insert the plugs and/or grease nipples, making sure that they are properly tightened.
6. During lubrication operations, always check that the floating part is axially free. If the movement is blocked, open the coupling and check the gear teeth.
7. Completely replace the grease every 8000 operating hours or at the latest every two years. For this activity you will have to open the coupling, clean the flange surfaces, remove all the old grease, clean the interstices, check the gear teeth condition and then perform the operations indicated in points 1 and 4. Never use contaminated grease, or grease which is not suitable to the working conditions.. Do not use tools to separate the two flanges of the toothed sleeves that could damage the integrity of the sealing surfaces.

To lubricate coupling and gear teeth, must be used lithium soap lubricating greases, with EP additives, resistant to centrifugation, non-hygroscopic and antioxidants .

For the first lubrication HDF S.r.l. uses VANGUARD LIPLEX EP 2 grease, NLGI 2 classification, with Complex Lithium soap thickener.

If you need to use other grease you must completely remove the grease and lubricate as a first filling.

The indications are to be considered summarized. It is essential to refer to the manufacturer's instructions.

7.2.14.2 Lubrication of lamellar couplings

The lamellar couplings do not require special maintenance.

Check the pairings of gears regularly, every 3-4 months.

When doing this, it is necessary to check that all the parts are not worn and are in good condition (for example cracks, signs of rubbing and wear, etc.)

Always consult the manufacturer's maintenance manual for all the necessary information.

7.2.15 Check of all the electrical system components



NOTE

This operation must only be done by the ELECTRICAL MAINTENANCE TECHNICIAN

- wear of the wires, that they are intact and not stripped;
- wires are tight on the terminal boards;
- wear of the screw terminals;
- wear of the switch contacts;
- electric boxes seal;
- wear of the connectors.

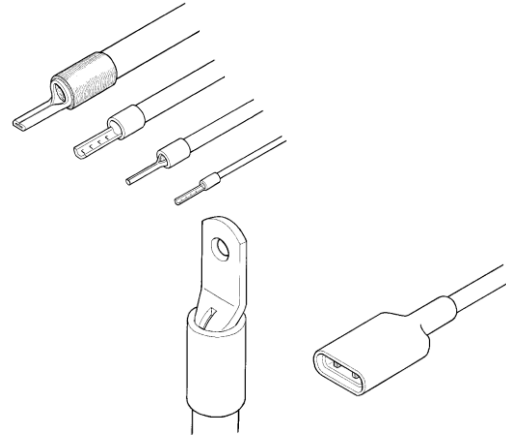

7.2.16 Check of the legibility of the warning labels for residual risks, restrictions and obligations

- Check they are legible, not worn and intact;
- If necessary: replace them immediately.;

Contact **HDF S.r.l.** for spare parts.



Note

The new parts replacing faulty ones must have the same technical characteristics and the same performance; if they are safety components, they must be certified and belong to the same class as those replaced.

7.2.17 Installation of the inlet control damper

Parallel blade dampers are used to control the air intake and reduce the consumption in applications where it is necessary to adjust the fan capacity based on the operating conditions. The dampers are unidirectional, can be supplied separately or installed on the fan and can come with manual control or with control actuators. To install the actuators, follow the instructions in the installation and maintenance manual of the actuator manufacturer. The control dampers must be installed according to the diagram below; when the dampers are engaged, the air flow should direct the air vortex in the direction of rotation of the impeller. The maintenance, check and repair intervals match those of the fan impeller.

Circular control dampers (dapò) are used, just like the parallel blade dampers, to control the air intake and reduce the consumption in applications where it is necessary to adjust the fan capacity based on the operating conditions. Follow the same installation recommendations indicated for the parallel blade dampers. Just like all control dampers, the dapò dampers should also be installed according to the discharge position shown below; when the dampers are engaged, the air flow should create an air vortex in the direction of rotation of the impeller. The maintenance, check and repair intervals match those of the fan impeller.

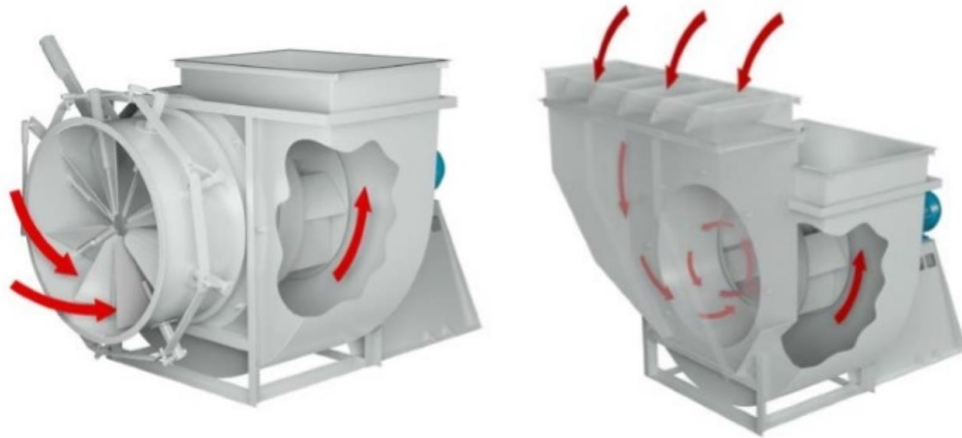

Note

Possible fan damages and faults if the control dampers (parallel blade or dapò dampers) are kept open to 30% constantly or for long periods of time. The 30% setting should be used only at start-up or for limited periods of time; it should not be used in a continuous manner. Do not keep the fan running with closed inlet/outlet for more than 15 minutes, unless it is explicitly authorized by **HDF S.r.l.**



WARNING CRUSHING/CUTTING HAZARD

Keep objects and hands away from the blades and/or moving parts of the dampers.

7.2.18 Seals Maintenance and start up

All the maintenance operations described above shall be performed when the fan is switched off following the safety rules described in chapter 2.

The following indications on startup procedures, set up, dismounting and assembly are mandatory and form an integral part of the Chapter 5. 6 and 7 of this manual.

SIMPLE SEAL

The Simple Seal does not require any particular kind of maintenance. It will be substituted when the leakage exceeds the allowable value, to be determined by the User on the basis of the application, or when the seal is damaged.

FLOATING SEAL

The Floating Seal does not require any particular kind of maintenance. The rings will be substituted when the leakage exceeds the allowable value, to be determined by the User on the basis of the application, or when the seal is damaged.

LABYRINTH SEAL

The Labyrinth Seal does not require any particular kind of maintenance. It will be substituted when the leakage exceeds the allowable value, to be determined by the User on the basis of the application, or when the seal is damaged.

CARBON RING SEAL

The Carbon Ring Seal does not require any particular kind of maintenance. The rings will be substituted when the leakage exceeds the allowable value, to be determined by the User on the basis of the application, or when the seal is damaged.

STUFFING BOX

If the fan is switched off for more than 2 calendar months, prior to start of the fan, it is suggested to verify and replace the stuffing box sealing material.

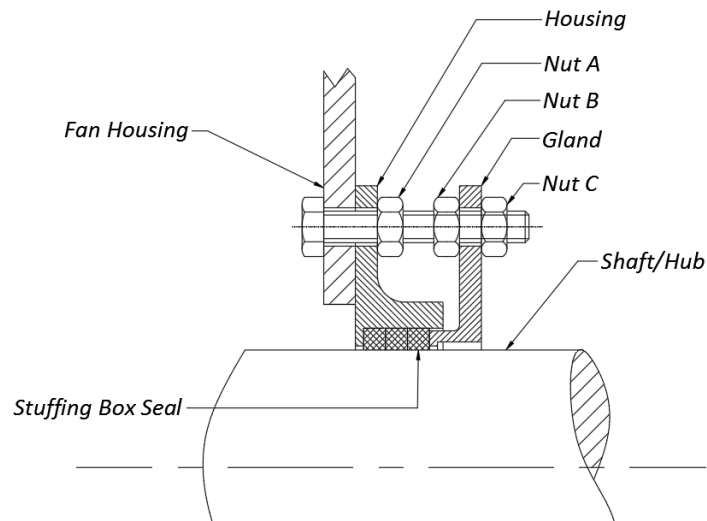

On the fans with Stuffing Box sealing system, during the first start up, the gland bolting shall not be tightened (just put in position by hand). **DO NOT** tighten the gland bolting before start. If possible, prior to first start-up, maintain the fan switched on for 30 minutes. This will allow the bearings, the stuffing box or the seal and the other parts to rotate which will reduce any eventual problems which may occur during future start-ups.

During the first startup of the fan, it is very important that the seal is not too much tightened. Refer to the Section **A.1 - Start up with a new Stuffing Box** for further information.

During the first start up, the seal should have a little leakage to guarantee the correct seal functionality in the future.

Attention: The Stuffing Box seal does not guarantee a 100% sealing.

A.1 - START UP WITH A NEW STUFFING BOX:

Verify that the "Nut A" is tightened. Verify that the "Nut B" is un-tightened and it will be never in contact with the gland during the seal regulation. Switch on the fan and run for 20 -30 minutes; Do not tighten the gland ("Nut C") even if the leakage is high. After this period, if the leakage is still higher than the allowable value, regulate the Stuffing Box as described in Section **A.2 - Stuffing Box regulation**. If the new Stuffing Box generates a high temperature during this period, turn off the fan and wait till it cools down.

A.2 - STUFFING BOX REGULATION

During the startup (not the first start up) slightly un-tighten the "Nut B" and verify that it will be never in contact with the gland during the seal regulation.

During the first start up, please verify that the "Nut B" shall be sufficiently loosened. If not, un-tighten as described above.

The allowable leakage ratio should be determined controlling the leak fluid temperature. It shall be cold or warm, **not hot**. During the seal regulation, tighten the nuts uniformly (cross tightening with dynamometer key) until the leakage is within the allowable ratio. The nuts shall be tightened with a nut maximum rotation equal to half turn. Between the steps it is necessary to have 30 minutes of seal running. Tighten the "Nut B" on the gland. If the seal is regulated correctly it will guarantee a good seal efficiency during its lifetime.

When it is impossible to achieve a correct regulation, the Stuffing box seal material shall be removed from the existing housing and substituted with a new kit.

If the fan is working with an aggressive , dangerous, toxic, hot, etc. fluid, the seal regulation shall be performed with the fan not connected to the plant; during this operation, the fluid shall be not dangerous and at ambient temperature.

A.3 - STUFFING BOX SEAL MAINTENANCE

The seal maintenance consists to tighten occasionally the gland when the leakage is higher than the admissible.

If the regulation does not decrease the leakage, the Stuffing Box sealing material shall be replaced with a new kit. For the-said operation, refer to Section **A.2 - Stuffing Box regulation**.

After 1 week from the fan start up, and in function of the seal wearing, define the maintenance interval according to the user requirements (**HDF S.r.l** suggests to have a maintenance interval not longer than 1 month).

A.4 - STUFFING BOX REPLACEMENT

1- Remove the gland and the sealing material. If the Stuffing box has the lantern ring, remove it.

2- Verify that there is not any damage on the shaft and on the housing surfaces. Repair or substitute the damaged components if seriously damaged. If the wearing is slight, machine the surfaces in order to obtain a smooth and concentric surface. Do not remove too much material.

3- Clean the housing groove.

4- After the preparation of the rings, start to put the rings inside the housing groove. It is fundamental that the first ring match exactly with the bottom of the groove. Slightly lubricate internally and externally the rings with oil. The ring junction cut shall be 90 deg. staggered. Do not put the seal material as a continuous spiral.

5- For startup procedure refer to **A.1 - Start up with new Stuffing Box**.

7.2.19 Thermocouple Maintenance and Regulation – Pt100

All the maintenance operations described above shall be performed when the **fan is switched off** following the safety rules described in chapter 2.

The following are the steps to follow for the correct fitting of the thermocouple, commonly called **RTD**.

As part of the HDF applications, is used Pt100 - platinum resistance thermometers (Pt), in which, the resistance at 0 ° C is 100 Ω (ISOIEC 60751) and the temperature coefficient equal to $\alpha = 0.003851 \text{ } ^\circ\text{C}^{-1}$.

Always consult the manufacturer's manual.

We always recommend using adjustable and non-fixed thermocouple.

Other types of Pt100 can be used, always consult the manual of the probes

ADJUSTABLE THERMOCOUPLE

For the assembly of the adjustable thermocouple is necessary:

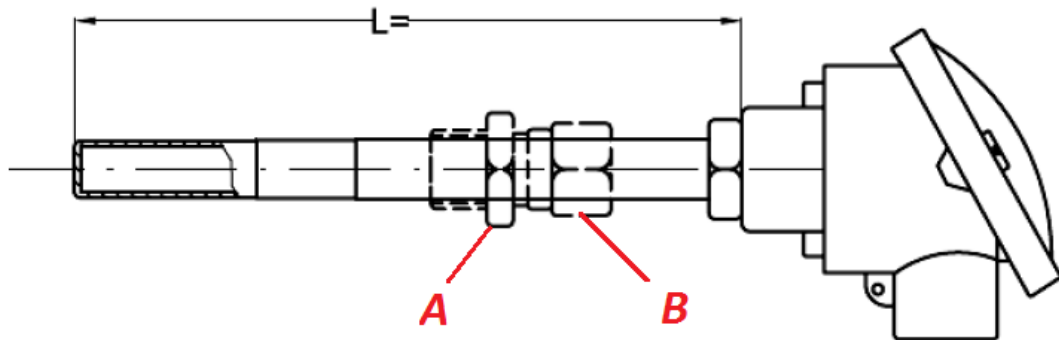

1. Make sure that the locking nut "B", which is used to lock the compression ring, is loosened.
2. Verify that the temperature probe can slide freely on the nipple "A".
3. Verify that the length of the threaded part of the nipple "A" is less than the depth of the hole that passes through the wall of the bearing housing. During the next tightening, the nipple should not come into contact with the outer ring of the bearing. If the wall thickness is insufficient to accommodate the nipple, provide for shims between this and the monoblock.



4. Secure the nipple "A" to the bearing housing without touching on the bearing outer ring. We recommend the use of a suitable sealing system between the bearing housing and nipple "A" (gasket or PTFE tape).

5. Slide the temperature probe until it reaches the bearing surface; make sure that the sensor is simply leaned and does not force on the outer ring.
6. Tighten locking nut "B".

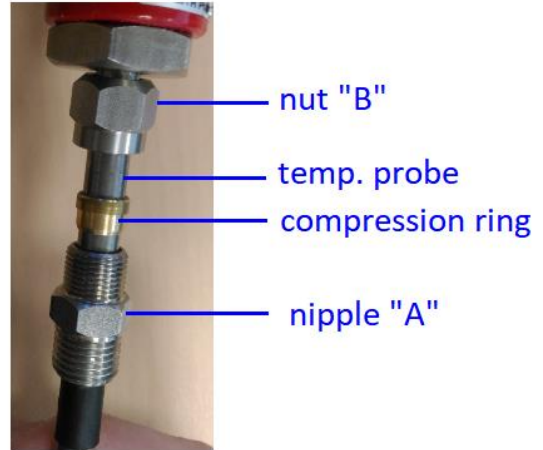

FIXED THERMOCOUPLE

For the assembly of the fixed thermocouple is necessary:

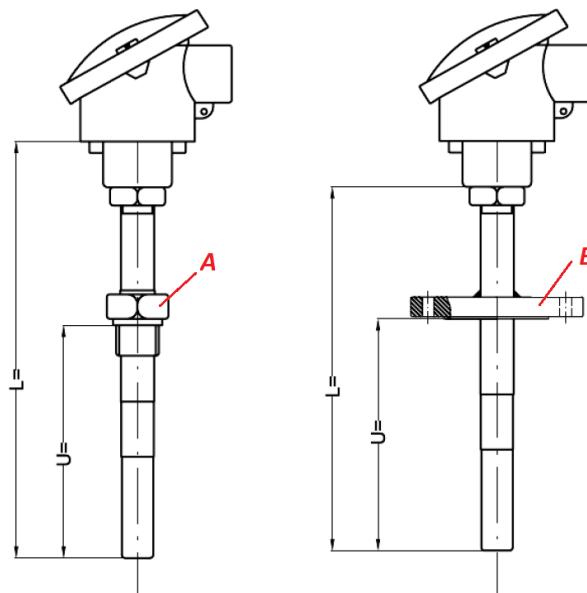

1. Verify that the length of the threaded part of the nipple "A" is less than the depth of the hole that passes through the wall of the support / monobloc. During the next tightening, the nipple should not come into contact with the outer ring of the bearing. If the wall thickness is insufficient to accommodate the nipple, provide for shims between this and the monobloc.
2. Verify that the length of the probe rod "U" (from the head to the bottom of the nipple "A" thread or of the fixing flange "B") is correct. Once tightened, the probe must not press but only lean against the bearing.
The probe must not generate additional stress on the mechanical components of the fan.
If necessary, provide adequate shims / spacers.

ASSEMBLY WITH BEARINGS "W33"

Some bearings, with designation W33, have a groove with holes on outer ring in order to grease the bearing directly from the center of the roller/ball crowns. The following figure shows an example.

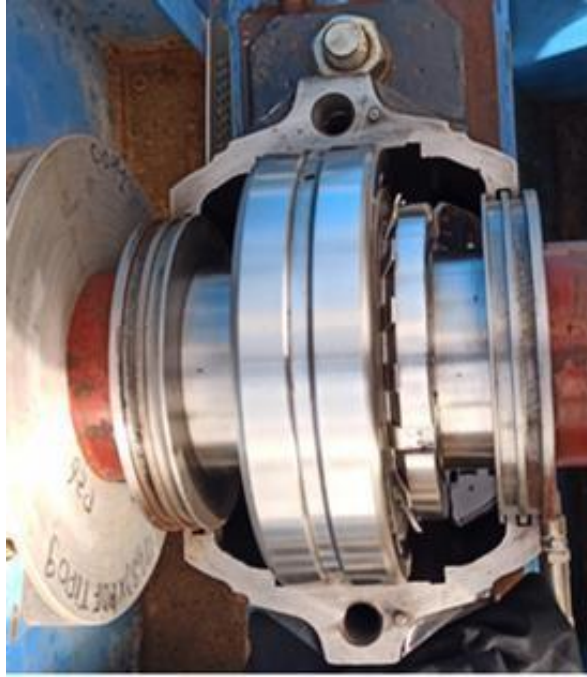

In this case it is mandatory to check that the sensor never exceeds the lodging machining on the support of the outer ring of the bearing as it would prevent the adaptation of the bearing, in particular the floating one, generating potential damage to both the sensors and the fan. An example schem is shown hereunder.

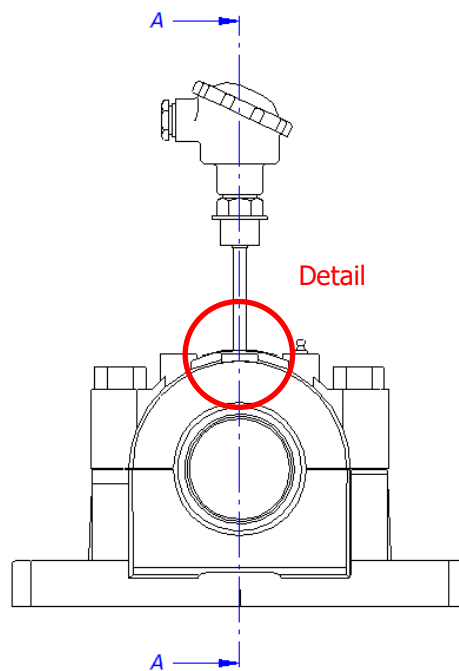

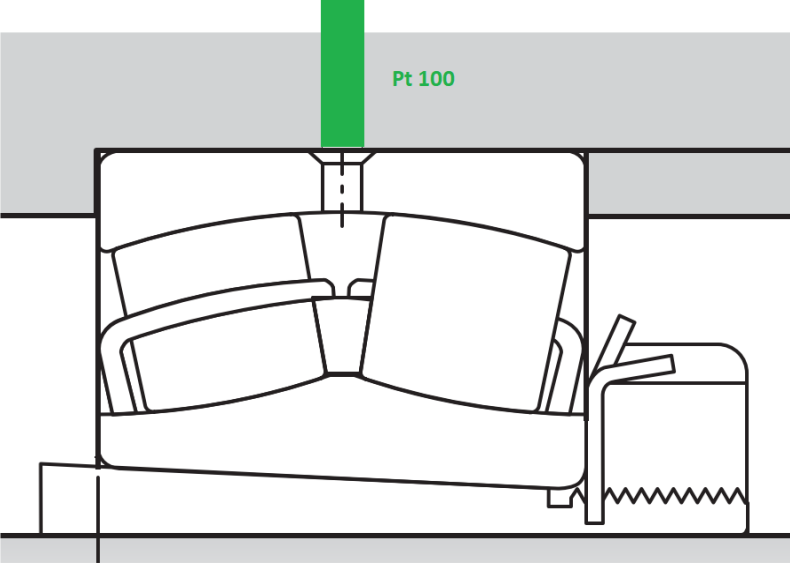
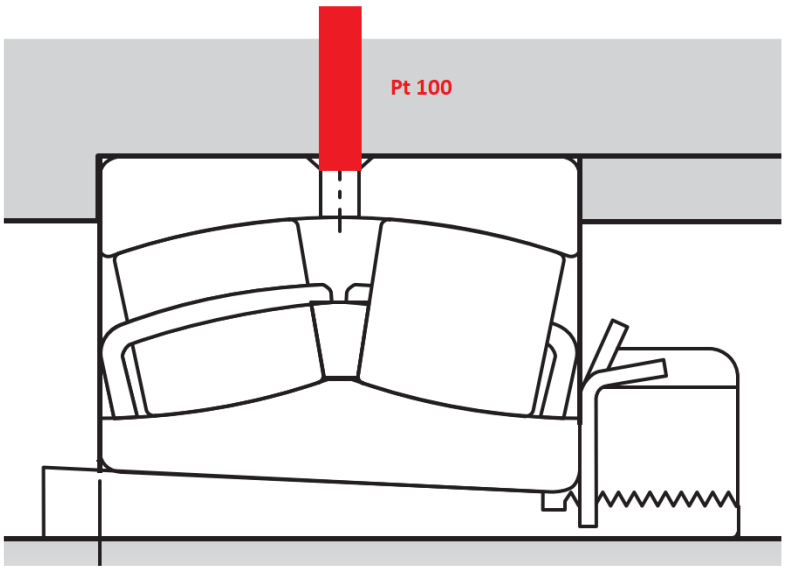

	<p>Correct assembly:</p> <p>The sensor <u>does not</u> interfere with the groove.</p>
	<p>Wrong assembly:</p> <p>The sensor interferes with the groove.</p>

8. TECHNICAL SUPPORT INFORMATION



For further information or technical support, contact **HDF S.r.l.** .

COMPANY NAME	HDF S.r.l.
ADDRESS	Via G. Meani 119 20861 Brugherio (MB) Italy
	(+39) 039 57 841 11
	(+39) 039 57 841 99
	info@hdfans.it
	www.hdfans.it

9. DISMANTLING AND DISPOSAL



Once the Fan has reached the end of its service life, it must be put out of service so it cannot be used for other purposes than those it was intended for and make possible the reuse of the parts and materials it is made from.

The Fan must be disabled and demolished in a safe manner, to avoid the risk of impact due to the presence of moving parts or stored energy.

In particular, disconnection operations of the pneumatic and electrical systems must be carried out according to the indications and warnings in Chapter 4 "Lifting and installation instructions".

HDF S.r.l. cannot be held in any way liable for damage to people or property due to re-use of the parts of the Fan for functions other than those initially intended by **HDF S.r.l.**



CAUTION

Before proceeding with any dismantling operations, the employees must have read and clearly understood the Safety Provisions (Chapter 2) at the beginning of this manual and wear the Personal Protective Equipment (protective gloves, safety shoes, overalls, goggles, etc.).



DO NOT DISPOSE OF POLLUTANTS SUCH AS OIL, GREASE, RAW MATERIAL WASTE, ETC. INTO THE ENVIRONMENT.



DURING DISMANTLING OPERATIONS, SEPARATE THE VARIOUS TYPES OF MATERIALS.

To carry out dismantling, follow the procedure indicated below, with **EXTREME CAUTION**.



WARNING

DANGER OF CUTTING, CRUSHING, IMPACT AND ABRASION.



Disconnect the service systems:

- the sheaths of the electrical system (disconnect the connectors or the cables from the terminal and wrap the sheaths on the various utilities);
- disconnect the air supply;
- disconnect the power supply and interface cable;
- disconnect the air supply pipe;
- remove all guards;
- dismantle all the structures and various components.

For each component when lifting:

- keep the lifting straps taught;
- loosen all the screws fixing the component without removing them;
- check the correct balance of the harnessed load;
- remove all the screws previously loosened;
- remove the component from the ground;
- lift it and place it on a pallet.

MUST BE DISPOSED OF BY SPECIFIC AUTHORISED COMPANIES, FOR EACH ELEMENT, AND IN COMPLIANCE WITH THE LEGISLATION IN FORCE.

10. SPARE PARTS

The **HDF** Fan is designed, built and uses suitably sized components to ensure high reliability over time.

Failure to comply with the maintenance schedule and incorrect use of the Fan (as indicated in this manual) may cause damages to the components.

When replacing parts, ***always use original spare parts*** that can be ordered directly from **HDF S.r.l.**

The use of non-original spare parts will render the warranty void and can also affect the proper operation of the Fan.

The parts are to be replaced only by HDF technicians or by qualified maintenance staff.



We recommend ordering the spare parts in advance based on the production requirements and on the time available for putting the Fan back in operation.

SPARE PARTS SUBJECT TO WEAR OVER TIME

- Bearings
- Pedestal/pillow block
- Seals
- Drive coupling
- Belts
- Pulleys
- Flexible connection
- Shock absorbers
- Impeller (in case of severe conditions)

SPARE PARTS SUBJECT TO EXTRAORDINARY REPLACEMENT

- Motors (*)



(*) components with delivery times of up to 6-8 weeks.

This is why HDF recommends ordering them in advance to avoid any excessive downtimes.



SPARE PART REQUEST

For spare part quotation request, contact the Technical Support Department at: service@hdfans.it

When ordering spare parts, please mention the following:

- model and job number of the Fan.
- number or code of the item.
- desired quantity.

11. TROUBLESHOOTING



Problem	Causes	Solution
Start-up failure	Excessive power absorption	Check the power absorption.
	Reduced power supply voltage	Check the mains voltage
	MAX. relay unsuitable for the start-up conditions.	Replace the max. relay with a suitable one.
	Electric motor fault that lower its inrush characteristics	Replace the electric motor.
	Inadequate assessment of the moment of inertia of the rotating parts of the fan in connection with the selected electric motor and its type of starter.	Install an electric motor with higher capacity or check the friction on the mechanical parts.
	Starting voltage too low.	Check the mains voltage.
Vibrations	Impeller imbalance.	Make sure there are no dust deposits or other materials on the rotating parts. Check the impeller for erosion or corrosion signs. If the impeller is seriously damaged, have it replaced
	Unsuitable foundation.	Reinforce the structure or decrease the natural resonant frequency by increasing the masses
	Loosen the foundation bolts or the fixing bolts of the bearings and their covers	Tighten the screws completely
	The head screw locks the loose impeller.	Tighten and check that the impeller is in the correct position
	The impeller rotates backwards	Check that the direction of rotation of the impeller is correct, as indicated on the nameplate
	Vibrations transmitted to the fan from the system, other machines or structures of the building.	Check the system in which the fan is installed. If necessary, install expansion joints between the fan and the ducts.
	Air pulses.	The fan is mechanically sized for a rotational speed 1.1 times higher than the Intended speed: this limit must not be exceeded if allowed by the electric motor.
	Using the fan at rotational speeds higher than the intended one	

Problem	Causes	Solution
Air pulses (pumping)	Fan running at reduced or zero capacity, usually at full pressure. The fan works in the stall region of the performance curve. This may be due to many causes including: <ul style="list-style-type: none"> • Accidental closing of the dampers installed on the system or on the fan • Circuit resistance different than that intended • Obstruction or incorrect inlet connection resulting in inconsistent air intake • Repeated detachment/reattachment of the confined fluid from/to the walls of a divergent duct 	Provide adequate systems to prevent the dampers from closing completely. Check the system.
Noise	Foreign materials in the fan casing.	Check the impeller and the fan casing: clean and remove any foreign bodies.
	Friction between static and rotating parts	Check the clearances and the tolerances between static and rotating parts and bolts' tightening periodically (every 6 months).
	Wrong choice of bearings.	Replace the bearings.
Performance with excessive capacity	Fan power unexpectedly high.	Make sure that the fan speed is not too high. Correct one or more of the following conditions: <ul style="list-style-type: none"> • the fan is treating ambient air while it was designed for hot or less dense air; • excessive pressure drop assessments (slow down the rotational speed of the fan or close the dampers partially).

Problem	Causes	Solution
Insufficient air flow	Incorrect fan rotation	Check the direction of rotation as shown on the nameplate
	Sudden changes of direction in the duct near the fan drain or pre-rotation of the fluid due to the elbow duct at the inlet.	Assess System Effect.
	Inlet flow regulator installed incorrectly	Make sure the flow regulator is installed with the air intake in the direction of rotation of the impeller when partially closed (see 7.2.17)
	Fan power unexpectedly low	Correct one or more of the following conditions: <ul style="list-style-type: none"> • pre-rotation of the fluid at the fan inlet; • resistance to fluid passage higher than calculated (caused for example by a closed damper).
Performance with excessive capacity	Fan power unexpectedly high.	Make sure that the fan speed is not too high. Correct one or more of the following conditions: <ul style="list-style-type: none"> • the fan is treating ambient air while it was designed for hot or less dense air; • excessive pressure drop assessments (slow down the rotational speed of the fan or close the dampers partially).

12. ATEX

12.1 Warnings



DANGER

Zones 0, 1 and 2 refer to gas while zones 20, 21 and 22 refer to dust.

Zone 0 A place in which an explosive atmosphere consisting of a mixture with air of flammable substances in the form of gas, vapour or mist is present continuously or for long periods or frequently.

Zone 1 A place in which an explosive atmosphere consisting of a mixture with air of flammable substances in the form of gas, vapour or mist is likely to occur in normal operation occasionally.

Zone 2 A place in which an explosive atmosphere consisting of a mixture with air of flammable substances in the form of gas, vapour or mist is not likely to occur in normal operation but, if it does occur, will persist for a short period only.

Zone 20 A place in which an explosive atmosphere in the form of a cloud of combustible dust in air is present continuously, or for long periods or frequently.

Zone 21 A place in which an explosive atmosphere in the form of a cloud of combustible dust in air is likely to occur in normal operation occasionally.

Zone 22 A place in which an explosive atmosphere in the form of a cloud of combustible dust in air is not likely to occur in normal operation but, if it does occur, will persist for a short period only.

ATTENTION: CHOOSING TO INSTALL A FAN THAT COMPLIES OR DOES NOT COMPLY WITH THE ATEX DIRECTIVE 2014/34/UE IS AT THE DISCRETION OF THE END USER, WHO WILL ASSUME FULL RESPONSIBILITY.

Before installing the fan, you must:

- 1) Perform a risk assessment of the environment in which it will be installed;
- 2) identify the type of hazardous atmosphere present in the environment (gas or dust);
- 3) define the zones (see):
 - for atmospheres subject to the presence of gases, refer to zones from 0 to 2 (from high to low risk of explosion);
 - for atmospheres subject to the presence of dust, refer to zones from 20 to 22 (from high to low risk of explosion);
- 4) define the product category (1-2-3) (see Directive 99/92/EC);
- 5) check the correspondence of data shown on the nameplate affixed to the fan.

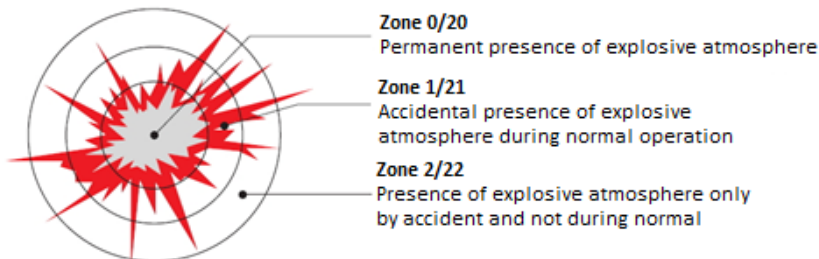

ZONE	Atmosphere	Group	Category	Protection Method	Temperature Class
ZONE 1	Gas	II	2G	c	T1 - T6
ZONE 2	Gas	II	3G	c	T1 - T6
ZONE 21	Dust	II	2D	c	T 125 or >
ZONE 22	Dust	II	3D	c	T 125 or >

12.2 Construction features

The fans that comply with Directives 2014/34/UE are designed to prevent the formation of sparks as a result of the friction between the rotating and fixed parts.

The features below must be checked before installing the fan:

- 1) Copper/brass/aluminium plates between the inlet cone and the impeller;
- 2) Copper/brass/aluminium rings:
 - Between the casing and the electric motor shaft;
 - (On indirect drive fans only) Between the pulleys and the guard;
- 3) (On indirect drive fans only) Adequate belts;
- 4) (For fan with kW>11 only) Welded casing;
- 5) Grounding (loose parts). It is necessary to check the connection of the fan with a grounding system.

12.3 Internal and External zones

According to the classification of the external zone in which the fan is installed and the internal zone of the machine, the 2014/34/UE directive defines the technical and constructive requirements of ATEX fans.

Note: If motor is operated by inverter, it is necessary to provide and install PTC or PT100.

		INTERNAL		EXTERNAL	
		CLASSIFICATION ZONE	APPLICATION GROUP	CLASSIFICATION ZONE	APPLICATION GROUP
GAS	ZONE 1		2G	ZONE 1	2G
				ZONE 2	3G
	ZONE 2		3G	NO-ZONE	
				ZONE 2	3G
				ZONE 1	2G
NO ZONE			ZONE 2	3G	
DUST	ZONE 21		2 D	ZONE 21	2D
				ZONE 22	3D
	ZONE 22		3D	NO-ZONE	
				ZONE 22	3D
				ZONE 21	2D
NO ZONE			ZONE 22	3D	

The **HDF S.r.l.** Fan is designed, built and uses suitably sized components to ensure high reliability over time.















Failure to comply with the maintenance schedule and incorrect use of the Fan (as indicated in this manual) may cause damages to the components.

When replacing parts, **always use original spare parts** that can be ordered directly from **HDF S.r.l.**

The use of non-original spare parts will render the warranty void and can also affect the proper operation of the Fan.

12.3 Atex Marking – Name plate

Below is an example of ATEX marking adopted by HDF.

		HDF S.r.l. Via Nazionale, 5/C Zona Artigianale 23030 Chiuro (SO) - ITALY tel/phone: +39 0342 484011 fax: +39 0342 483059 info@hdfans.it www.hdfans.it		
VENTILATORE TIPO FAN TYPE		COMMESSA JOB		
MATRICOLA SERIAL NUMBER		ANNO COSTRUZIONE MANUFACTURE YEAR		
POTENZA INSTALLATA INSTALLED POWER		T. FLUIDO DI PROCESSO FLUID OPERATING T.		
ROTAZIONE ROTATION		RPM NOMINALI RATED RPM		
ES. COSTRUTTIVA ARRANGEMENT				
MARCATURA ATEX ATEX MARKING		FASCICOLO TECNICO TECHNICAL DOSSIER		
				

 **II 2G Ex h IIB T4 Gb**

Equipment protection level Gas: Gb, Gc
Equipment protection level Dust: Db, Dc

GAS - Maximum surface temperature:
 T1: Maximum surface temperature = 450°C
 T2: Maximum surface temperature = 300°C
 T3: Maximum surface temperature = 200°C
 T4: Maximum surface temperature = 135°C
DUST - Maximum surface temperature:
 T xxx: Maximum surface temperature = xxx°C

Gas Group: IIA, IIB
Dust Group: IIIA, IIIB or IIIC

Level of constructive protection

ATEX Category (GAS): 2G or 3G
ATEX Category (DUST): 2D or 3D

Application Group II: other sites different from underground (Group I)

ATEX symbol

EX h correspondence to Non electrical type of protection constructional safety 'c'

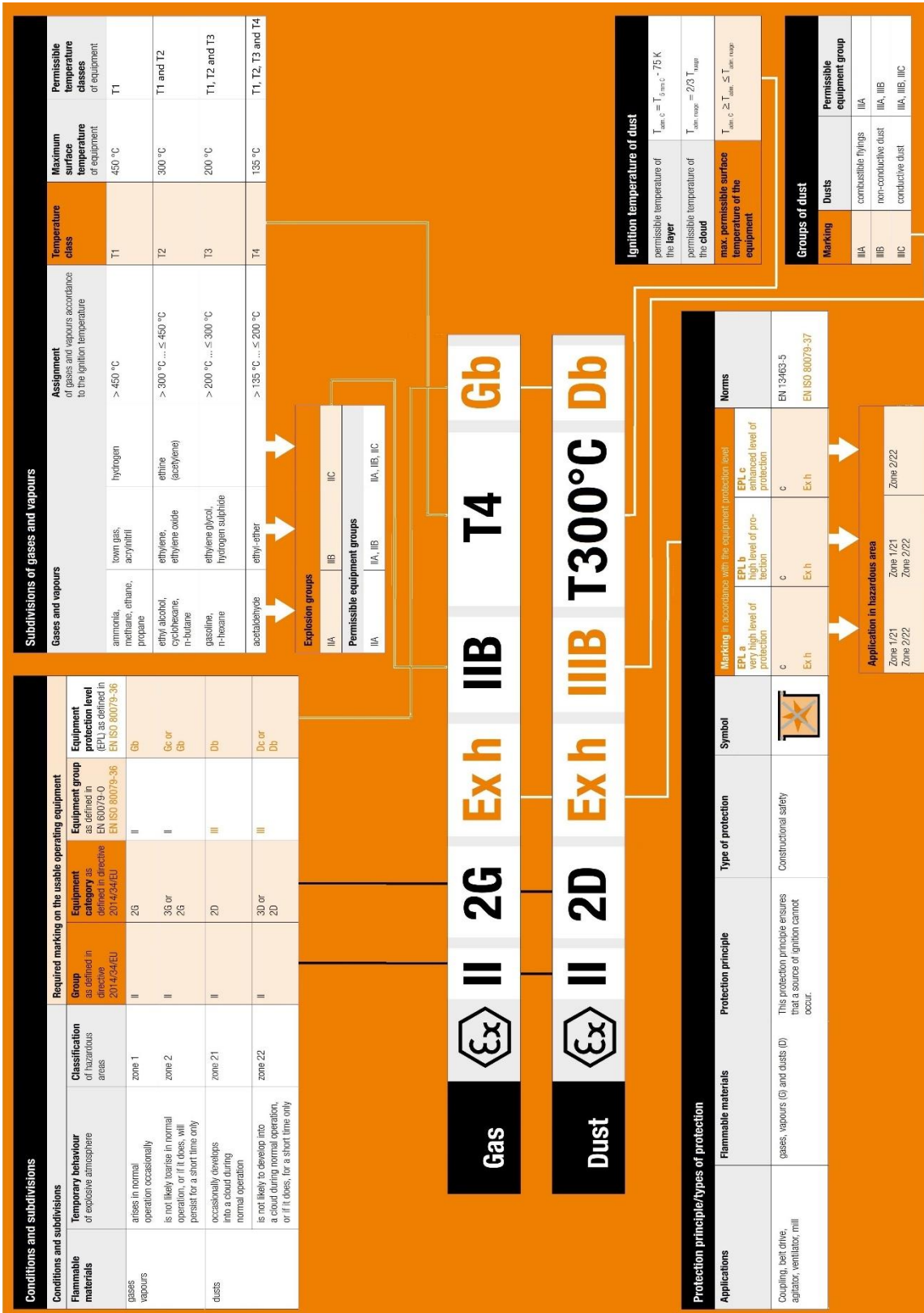



**HDF S.r.l.
STABILIMENTO
Via G. Meani 119
20861 Brugherio (MB)
ITALIA**